



CLOVER DISPLAY LTD.

LCD MODULE SPECIFICATION

Model: CV9018A - _ _ - _ _ - _ _ - _

Revision	11
Engineering	Steven Doo
Date	21 February 2020
Our Reference	9018

ADDRESS : 1st FLOOR, EFFICIENCY HOUSE, 35 TAI YAU STREET, SAN PO KONG,
KOWLOON, HONG KONG.

TEL : (852) 2341 3238 (SALES OFFICE) (852) 2342 8228 (GENERAL OFFICE)

FAX : (852) 2357 4237 (SALES OFFICE)

E-MAIL : cdl@cloverdisplay.com

URL : <http://www.cloverdisplay.com>

MODE OF DISPLAY**Display mode**

- STN : Yellow green
 Grey
 Blue (negative)
 FSTN positive
 FSTN negative

Display condition

- Reflective type
 Transflective type
 Transmissive type
 Others

Viewing direction

- 6 O' clock
 12 O' clock
 3 O' clock
 9 O' clock

LCD MODULE NUMBER NOTATION:

CV9018A- N N - S R - N 6 - T
| | | | | | | |
(1) (2) (3) (4) (5) (6) (7) (8)

*(1)---Model number of standard LCD Modules

*(2)---Backlight type

- N – No backlight
E – EL backlight
L – Side-lited LED backlight
M– Array LED backlight
C – CCFL

*(3)---Backlight color

- N – No backlight
A – Amber
B – Blue
O– Orange
W–White
Y – Yellow green
R – Red
G – Green

*(4)---Display mode

- T – TN
V – TN (Negative)
S – STN Yellow green
G – STN Grey
B – STN Blue (Negative)
F – FSTN
N – FSTN (Negative)

*(5)---Rear polarizer type

- R – Reflective
F – Transflective
T – Transmissive

*(6)---Temperature range

- N – Normal
W– Extended

*(7)---Viewing direction

- 6 – 6 O'clock
2 – 12 O'clock
3 – 3 O'clock
9 – 9 O'clock

*(8)---Special code for other requirements
(Can be omitted if not used)

GENERAL DESCRIPTION

Display mode : 98 x 64 dots, Graphic COG LCD module
 Interface : Serial
 Driving method : 1/65 duty, 1/9 bias
 Controller IC : Sitronix ST7565P or equivalent
 For the detailed information, please refer to the IC specifications.

MECHANICAL DIMENSIONS

Item	Dimension	Unit	Item	Dimension	Unit
Outline Dimension			Viewing Area	34.0(L)x22.0(W)	mm
No Backlight (N)	37.0(L)x33.0(W)x2.15max.(H)	mm	Dot Pitch	0.30(L)x0.30(W)	mm
LED Side Backlight(L)	37.0(L)x33.0(W)x4.50max.(H)	mm	Dot Size	0.27(L)x0.27(W)	mm

CONNECTOR PIN ASSIGNMENT

Pin No.	Symbol	Function
1	V0	Power supply for LCD
2	V1	Power supply for LCD
3	V2	Power supply for LCD
4	V3	Power supply for LCD
5	V4	Power supply for LCD
6	CAP2N	Voltage converter
7	CAP2P	Voltage converter
8	CAP1P	Voltage converter
9	CAP1N	Voltage converter
10	CAP3P	Voltage converter
11	Vout	Voltage converter
12	VSS	Ground
13	VDD	Supply voltage for logic
14	D7(SI)	Serial data input pin
15	D6(SCL)	Serial clock input pin
16	A0	Register select input
17	/res	External reset input
18	/CS1	Chip Select
* 19	A	Supply voltage for backlight(+VE)
* 20	K	Supply voltage for backlight(-VE)

Note (*): Pin 19, 20 are used for backlight version.

COUNTER DRAWING OF MODULE DIMENSION

MARK	REASON	PREPARED	DATE
△	Add Blue colour side-lit backlight	Brian	04 AUG 04
△	Change IC & modify backlight specification	Hermus	13 DEC 07
△	Add green & red colour side-lit backlight	Timmy	11 MAY 10
△	Changed the cable from heat-seal to FPC	MYWONG	25 SEP 19

NO backlight version
Side-lit backlight version

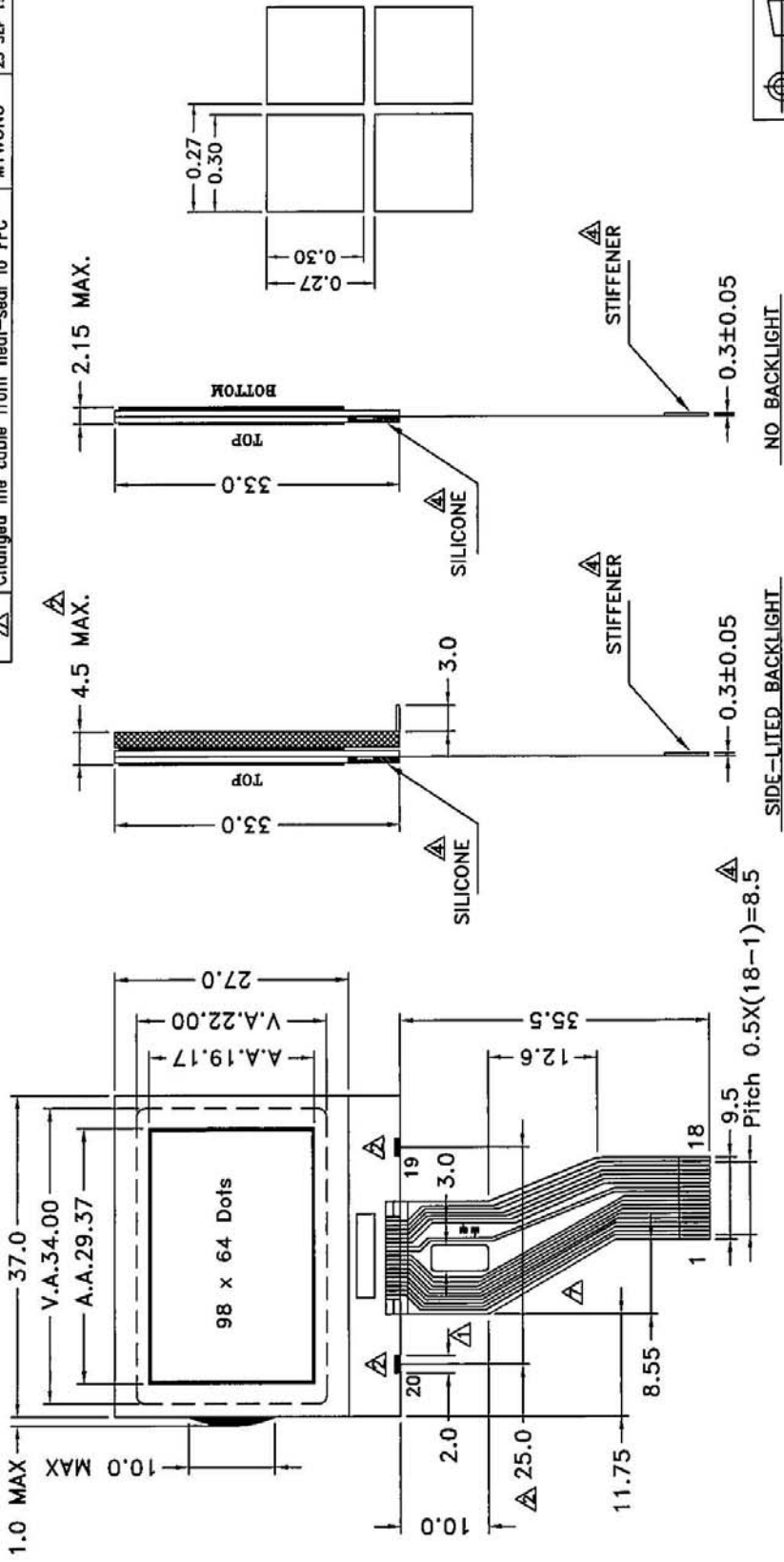

REV.	REVISION RECORD	SCALE	UNIT IN mm	DATE
02	Add Backlight version CD drawing	N.T.S.	mm	16 MAY 03
03	Revise Terminology for Backlight		mm	08 SEP 03
04	Add blue colour side-lit backlight		mm	05 AUG 04
05	Change IC & modify backlight specification		mm	13 DEC 07
06	Add green & red colour side-lit backlight		mm	11 MAY 10
07	Changed the cable from heat-seal to FPC		mm	25 SEP 19

TOLERANCE IF NOT SPECIFY	±0.5mm
CUSTOMER	CLOVER DISPLAY LTD. (HK)
AGENT	STANDARD
CUSTOMER REF.	OUR REF. X9018
DATE	16 MAY 03
DATE	08 SEP 03
DATE	05 AUG 04
DATE	13 DEC 07
DATE	11 MAY 10
DATE	25 SEP 19
DATE	04 AUG 04
DATE	13 DEC 07
DATE	11 MAY 10
DATE	25 SEP 19

COUNTER DRAWING OF PIN OUT & BLOCK DIAGRAM

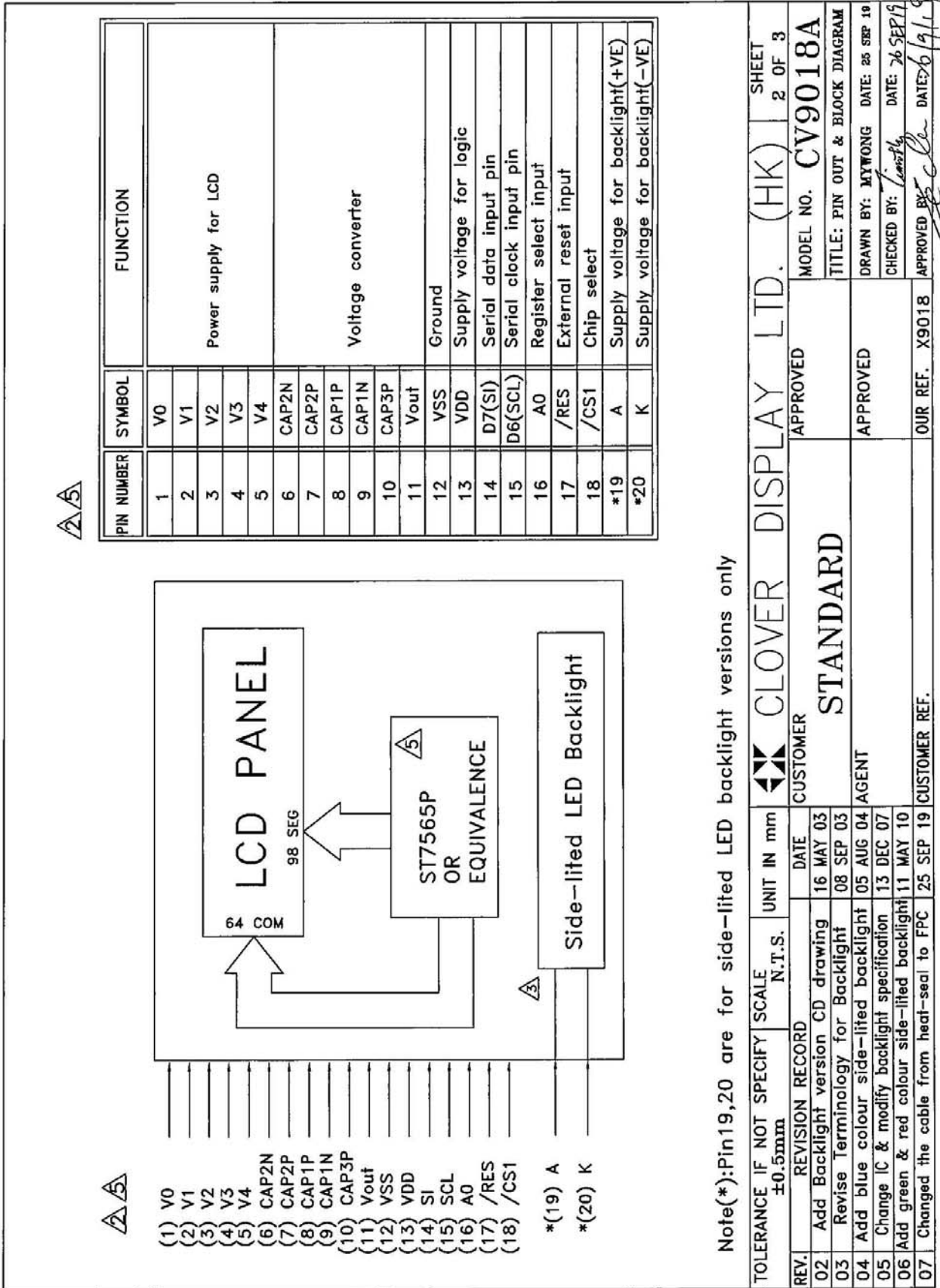

Note(*):Pin19,20 are for side-lit LED backlight versions only

TOLERANCE IF NOT SPECIFY ±0.5mm		SCALE N.T.S.	UNIT IN mm	CLOVER DISPLAY LTD. (HK)		SHEET 2 OF 3
REV.	REVISION RECORD	DATE	CUSTOMER	APPROVED		MODEL NO. CV9018A
02	Add Backlight version CD drawing	16 MAY 03	STANDARD	APPROVED		TITLE: PIN OUT & BLOCK DIAGRAM
03	Revise Terminology for Backlight	08 SEP 03	AGENT	APPROVED		DRAWN BY: MYWONG DATE: 25 SEP 19
04	Add blue colour side-lit backlight	05 AUG 04				CHECKED BY: <i>Leung</i> DATE: 26 SEP 19
05	Change IC & modify backlight specification	13 DEC 07				APPROVED BY: <i>Leung</i> DATE: 26 SEP 19
06	Add green & red colour side-lit backlight	11 MAY 10				
07	Changed the cable from heat-seal to FPC	25 SEP 19	CUSTOMER REF.	OUR REF. X9018		

ELECTRICAL CHARACTERISTICS

Conditions: VSS=0V, Ta=25°C

Item	Symbol	MIN.	TYP.	MAX.	Unit	Item	Symbol	MIN.	TYP.	MAX.	Unit
Supply Voltage	VDD	2.75	3.00	3.30	V	“H”Level Input Voltage	VIH	0.8 VDD	—	VDD	V
Supply Current	IDD	—	181	300	Ma	“L”Level Input Voltage	VIL	0	—	0.2 VDD	V
Power supply for LCD control (*)	VOUT	7.60	8.00	8.40	V	—	—	—	—	—	—

(*) **Note 1: For Optimum Contrast, please note the follow software settings:**

- 1) Power Control Set (VC, VR, VF)=(1, 1, 1)
- 2) V0 voltage regulator internal resistor ratio set(D2, D1, D0)=(1, 0, 0)
- 3) Electronic volume mode set electronic volume register set(D5, D4, D3, D2, D1, D0)=(0, 1, 1, 0, 1, 0)
- 4) Please refer to below circuit for (3X Booster)

(*) **Note 2: There is tolerance in optimum LCD driving voltage during production and it will be within the specified range.**

CONNECTION EXAMPLE

3X Boosting Circuit

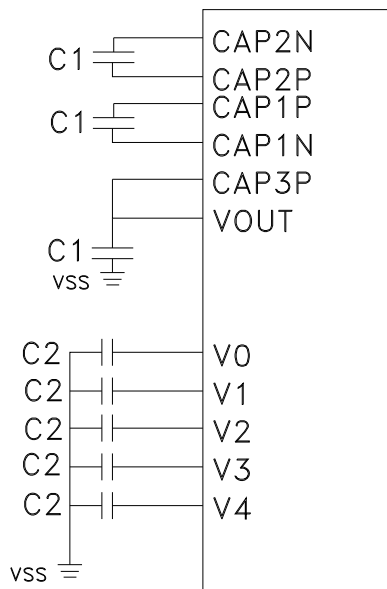

Item	Set value	Units
C1	1.0 to 4.7	uF
C2	0.1 to 4.7	uF

Side Backlight:

Constant voltage driving:

Item	Symbol	MIN.	TYP.	MAX.	Unit	Condition
Blue Backlight current	IBL	—	30	40	Ma	VBL = 3.6V
White Backlight current	IBL	—	30	40	Ma	VBL = 3.6V
Red Backlight current	IBL	—	30	40	Ma	VBL = 3.6V
Green Backlight current	IBL	—	20	30	Ma	VBL = 3.6V

ABSOLUTE MAXIMUM RATINGS

Please make sure not to exceed the following maximum rating values under the worst application conditions

Item	Symbol	Rating (for normal temperature)	Rating (for wide temperature)	Unit
Supply Voltage	VDD	0.3 to 3.6	0.3 to 3.6	V
Operating Temperature	Topr	0 to 50	-20 to 70	°C
Storage Temperature	Tstg	-10 to 60	-30 to 80	°C

INSTRUCTION TABLE

Command	Command Code										Function		
	A0	/RD	/WR	D7	D6	D5	D4	D3	D2	D1		D0	
(1) Display ON/OFF	0	1	0	1	0	1	0	1	1	1	0	1	LCD display ON/OFF 0: OFF, 1: ON
(2) Display start line set	0	1	0	0	1	Display start address						Sets the display RAM display start line address	
(3) Page address set	0	1	0	1	0	1	1	Page address				Sets the display RAM page address	
(4) Column address set upper bit	0	1	0	0	0	0	1	Most significant column address				Sets the most significant 4 bits of the display RAM column address.	
Column address set lower bit	0	1	0	0	0	0	0	Least significant column address				Sets the least significant 4 bits of the display RAM column address.	
(5) Status read	0	0	1	Status				0	0	0	0	0	Reads the status data
(6) Display data write	1	1	0	Write data							Writes to the display RAM		
(7) Display data read	1	0	1	Read data							Reads from the display RAM		
(8) ADC select	0	1	0	1	0	1	0	0	0	0	0	1	Sets the display RAM address SEG output correspondence 0: normal, 1: reverse
(9) Display normal/reverse	0	1	0	1	0	1	0	0	1	1	0	1	Sets the LCD display normal/reverse 0: normal, 1: reverse
(10) Display all points ON/OFF	0	1	0	1	0	1	0	0	1	0	0	1	Display all points 0: normal display 1: all points ON
(11) LCD bias set	0	1	0	1	0	1	0	0	0	1	0	1	Sets the LCD drive voltage bias ratio 0: 1/9 bias, 1: 1/7 bias (ST7565P)
(12) Read/modify/write	0	1	0	1	1	1	0	0	0	0	0	0	Column address increment At write: +1 At read: 0
(13) End	0	1	0	1	1	1	0	1	1	1	0	0	Clear read/modify/write
(14) Reset	0	1	0	1	1	1	0	0	0	1	0	0	Internal reset
(15) Common output mode select	0	1	0	1	1	0	0	0	0	*	*	*	Select COM output scan direction 0: normal direction 1: reverse direction
(16) Power control set	0	1	0	0	0	1	0	1	Operating mode			Select internal power supply operating mode	
(17) V ₀ voltage regulator internal resistor ratio set	0	1	0	0	0	1	0	0	Resistor ratio			Select internal resistor ratio(R _b /R _a) mode	
(18) Electronic volume mode set Electronic volume register set	0	1	0	1	0	0	0	0	0	0	0	1	Set the V ₀ output voltage electronic volume register
(19) Static indicator ON/OFF Static indicator register set	0	1	0	1	0	1	0	1	1	0	0	1	0: OFF, 1: ON Set the flashing mode
(20) Booster ratio set	0	1	0	1	1	1	1	1	0	0	0	0	select booster ratio 00: 2x,3x,4x 01: 5x 11: 6x
(21) Power saver													Display OFF and display all points ON compound command
(22) NOP	0	1	0	1	1	1	0	0	0	1	1	1	Command for non-operation
(23) Test	0	1	0	1	1	1	1	*	*	*	*	*	Command for IC test. Do not use this command

DISPLAY DATA RAM (DDRAM)

The display data RAM stores the dot data for the LCD. It has a 65 (8 page x 8 bit +1) x 132 bit structure. As is shown in Figure 3, the D7 to D0 display data from the MPU corresponds to the LCD display common direction; there are few constraints at the time of display data transfer when multiple ST7565P are used, thus and display structures can be created easily and with a high degree of

freedom. Moreover, reading from and writing to the display RAM from the MPU side is performed through the I/O buffer, which is an independent operation from signal reading for the liquid crystal driver. Consequently, even if the display data RAM is accessed asynchronously during liquid crystal display, it will not cause adverse effects on the display (such as flickering).

D0	0	1	1	1		0
D1	1	0	0	0		0
D2	0	0	0	0		0
D3	0	1	1	1		0
D4	1	0	0	0		0
-						

Display data RAM

COM0						
COM1						
COM2						
COM3						
COM4						
-						

Liquid crystal display

The page address circuit

Page address of the display data RAM is specified through the Page Address Set Command. The page address must be specified again when changing pages to perform access.

Page address 8 (D3, D2, D1, D0 = 1, 0, 0, 0) is a special RAM for icons, and only display data D0 is used. (see Figure 4)

The column addresses

The display data RAM column address is specified by the Column Address Set command. The specified column address is incremented (+1) with each display data read/write command. This allows the MPU display data to be accessed continuously. Moreover, the incrementing of column addresses stops with 83H. Because the column address is independent of the page address, when moving, for example, from page 0 column 83H to page 1 column 00H,

it is necessary to respective both the page address and the column address. Furthermore, as is shown in Table 4, the ADC command (segment driver direction select command) can be used to reverse the relationship between the display data RAM column address and the segment output. Because of this, the constraints on the IC layout when the LCD module is assembled can be minimized. As is shown in Figure 4,

Table 4

SEG Output ADC	SEG0	SEG 131
(D0) "0"	0 (H) → Column Address →	83 (H)
(D0) "1"	83 (H) ← Column Address ←	0 (H)

The line address circuit

The line address circuit, as shown in Table 4, specifies the line address relating to the COM output when the contents of the display data RAM are displayed. Using the display start line address set command, what is normally the top line of the display can be specified (this is the COM0 output when the common output mode is normal, and the COM63 output

for ST7565P, the detail is shown page.11 The display area is a 65 line area for the ST7565P. If the line addresses are changed dynamically using the display start line address set command, screen scrolling, page swapping, etc. can be performed.

DISPLAY DATA RAM MAP

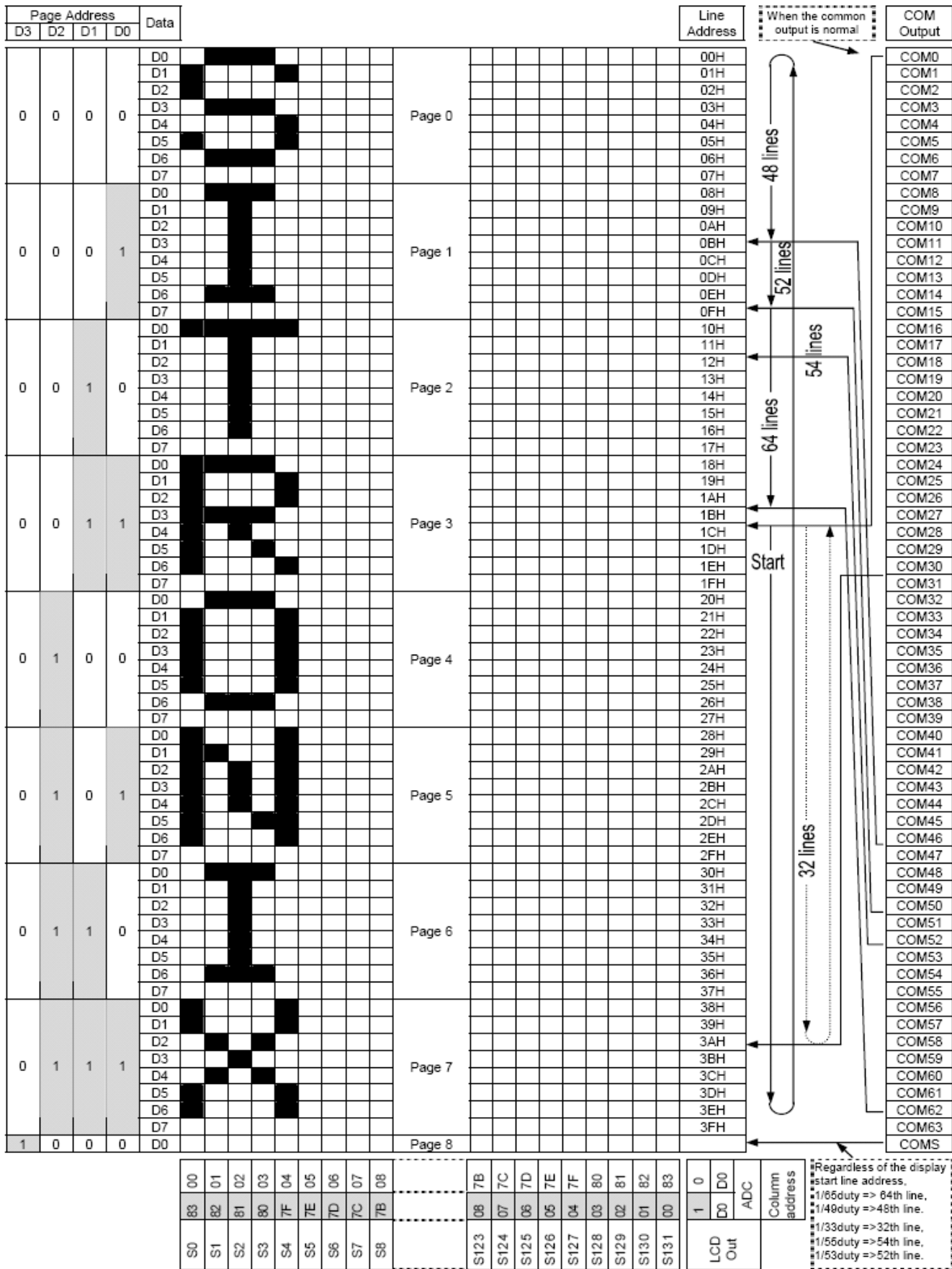

SERIAL INTERFACE TIMING CHARACTERISTICS

Item	Signal	Symbol	Condition	Rating		Units
				Min.	Max.	
Serial Clock Period	SCL	T_{scyc}		50	—	ns
SCL "H" pulse width		T_{shw}		25	—	
SCL "L" pulse width		T_{SLW}		25	—	
Address setup time	A0	T_{sAS}		20	—	
Address hold time		T_{sah}		10	—	
Data setup time	SI	T_{sds}		20	—	
Data hold time		T_{SDH}		10	—	
CS-SCL time	CS	T_{css}		20	—	
CS-SCL time		T_{csh}		40	—	

*1 The input signal rise and fall time(t_r, t_f) are specified at 15 ns or less.

*2 All timing is specified using 20% and 80% of V_{dd} as the standard.

SERIAL INTERFACE CHARACTERISTICS

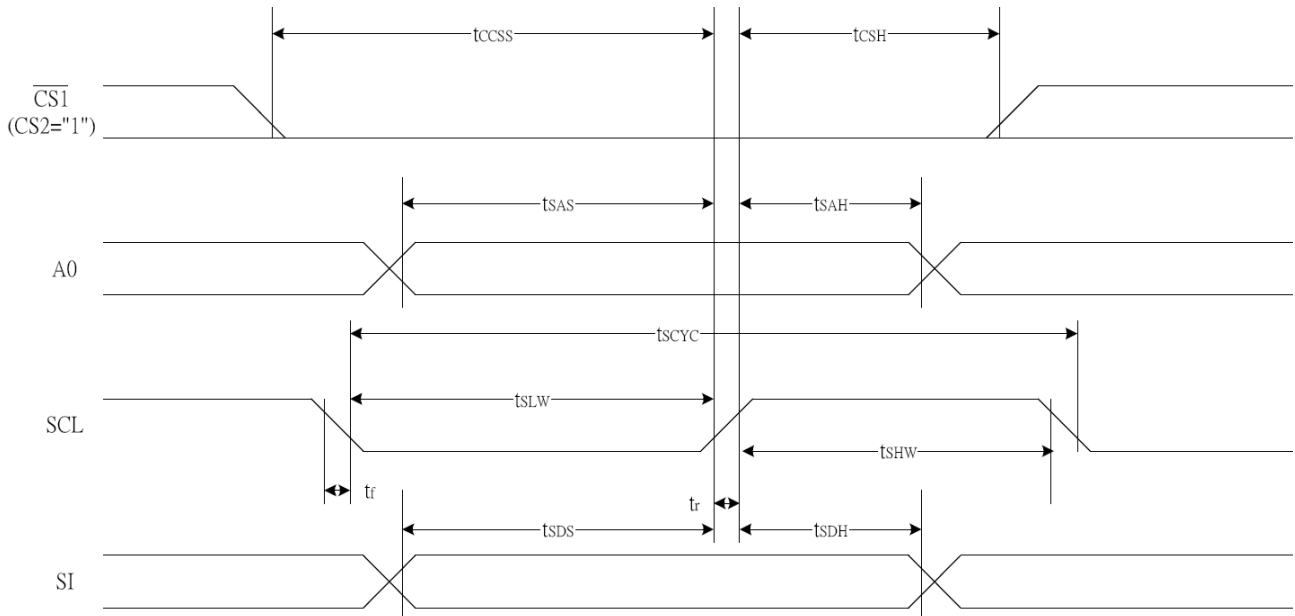

RESET TIMING

Item	Signal	Symbol	Condition	Rating			Units
				Min.	Typ.	Max.	
Reset time		t_r		—	—	1.0	us
Reset "L" pulse width	/RES	t_{RW}		1.0	—	—	us

*1 All timing is specified with 20% and 80% of V_{dd} as the standard

RESET TIMING DIAGRAM

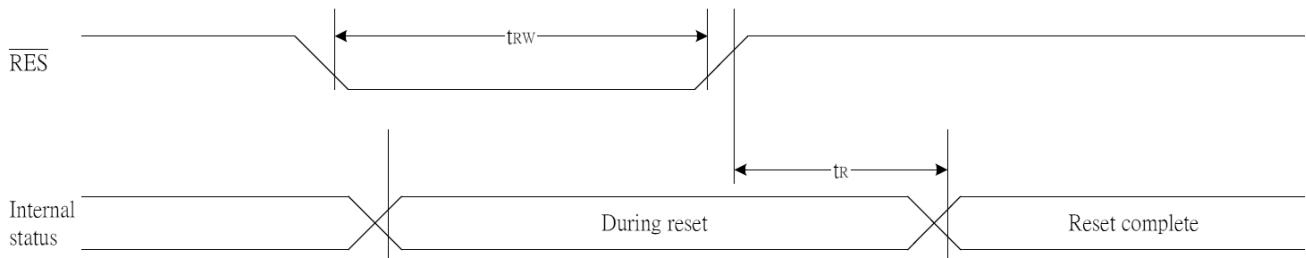

THE RESET CIRCUIT

When the /RES input comes to the "L" level, these LSIs return to the default state. Their default states are as follows:

1. Display OFF
2. Normal display
3. ADC select: Normal (ADC command D0 = "L")
4. Power control register: (D2, D1, D0) = (0, 0, 0)
5. Serial interface internal register data clear
6. LCD power supply bias rate:
 - 1/65 DUTY = 1/9 bias
 - 1/49, 1/55, 1/53 DUTY = 1/8 bias
 - 1/33 DUTY = 1/6 bias
7. All-indicator lamps-on OFF (All-indicator lamps ON/OFF command D0 = "L")
8. Power saving clear
9. Vo voltage regulator internal resistors Ra and Rb separation
10. Output conditions of SEG and COM terminals
SEG=VSS, COM=VSS
11. Read modify write OFF
12. Static indicator OFF Static indicator register : (D1, D2) = (0, 0)
13. Display start line set to first line
14. Column address set to Address 0
15. Page address set to Page 0
16. Common output status normal
17. Vo voltage regulator internal resistor ratio set mode clear
18. Electronic volume register set mode clear Electronic volume register :
(D5, D4, D3, D2, D1, D0) = (1, 0, 0, 0, 0, 0)
19. Test mode clear

On the other hand, when the reset command is used, the above default settings from 11 to 19 are only executed. When the power is turned on, the IC internal state becomes unstable, and it is necessary to initialize it using the /RES terminal. After the initialization, each input terminal should be controlled normally.

Moreover, when the control signal from the MPU is in the high impedance, an over current may flow to the IC. After applying a current, it is necessary to take proper measures to prevent the input terminal from getting into the high impedance state.

If the internal liquid crystal power supply circuit is not used on ST7565P, it is necessary that /RES is "H" when the external liquid crystal power supply is turned on. This IC has the function to discharge Vo when /RES is "L," and the external power supply short-circuits to V_{SS} when /RES is "L." While /RES is "L," the oscillator and the display timing generator stop, and the CL, FR, FRS and /DOF terminals are fixed to "H." The terminals D0 to D7 are not affected. The V_{SS} level is output from the SEG and COM output terminals. This means that an internal resistor is connected between V_{SS} and Vo.

When the internal liquid crystal power supply circuit is not used on other models of ST7565P series, it is necessary that /RES is "L" when the external liquid crystal power supply is turned on.

While /RES is "L," the oscillator works but the display timing generator stops, and the CL, FR, FRS and /DOF terminals are fixed to "H." The terminals D0 to D7 are not affected.

INITIALIZING WITH THE BUILT-IN POWER SUPPLY CIRCUITS

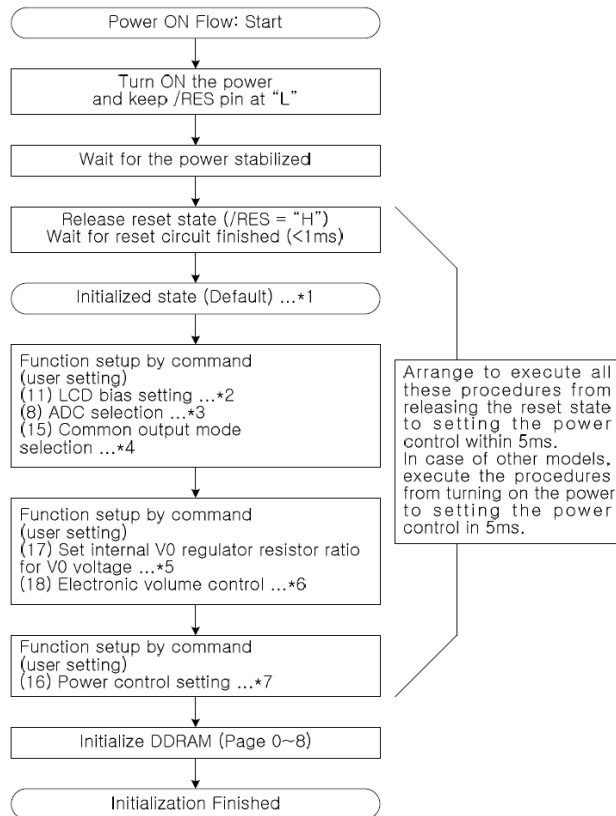

* The target time of 5ms will result to vary depending on the panel characteristics and the capacitance of the smoothing capacitor. Therefore, we suggest you to conduct an operation check using the actual equipment.

Notes: Refer to respective sections or paragraphs listed below.

*1: Description of functions; Resetting circuit

*2: Command description; LCD bias setting

*3: Command description; ADC selection

*4: Command description; Common output state selection

*5: Description of functions; Power circuit & Command description; Setting the built-in resistance ratio for regulation of the V0 voltage

*6: Description of functions; Power circuit & Command description; Electronic volume control

*7: Description of functions; Power circuit & Command description; Power control setting

ELECTRO-OPTICAL CHARACTERISTICS

MEASURING CONDITION: POWER SUPPLY = $V_{OP} / 64 \text{ Hz}$
 TEMPERATURE = $23 \pm 5 \text{ }^\circ\text{C}$
 RELATIVE HUMIDITY = $60 \pm 20 \%$

ITEM	SYMBOL	UNIT	TYP. STN
RESPONSE TIME	Ton	ms	220
	Toff	ms	280
CONTRAST RATIO	Cr	-	12
VIEWING ANGLE (6 O'clock) Cr ≥ 2	V3:00	°	40
	V6:00	°	70
	V9:00	°	40
	V12:00	°	50

THE ELECTRO-OPTICAL CHARACTERISTICS ARE MEASURED VALUE BUT NOT GUARANTEED ONES.

RELIABILITY OF LCD MODULE

ITEM	TEST CONDITION FOR NORMAL TEMPERATURE	TEST CONDITION FOR WIDE TEMPERATURE	TIME
High temperature operating	50°C	70°C	240 hours
Low temperature operating	0°C	-20°C	240 hours
High temperature storage	60°C	80°C	240 hours
Low temperature storage	-10°C	-30°C	240 hours
Temperature-humidity storage	40°C 90% R.H.	60°C 90% R.H.	96 hours
Temperature cycling	-10°C to 60°C 30 Min Dwell	-30°C to 80°C 30 Min Dwell	5 cycle
Vibration Test at LCM Level	Freq 10-55 Hz Sweep rate: 10-55-10 at 1 min Sweep mode Linear Displacement: 2 mm p-p 1 Hour each for X, Y, Z	Freq 10-55 Hz Sweep rate: 10-55-10 at 1 min Sweep mode Linear Displacement: 2 mm p-p 1 Hour each for X, Y, Z	—

SAMPLING METHOD

SAMPLING PLAN: ASNI/ASQ Z1.4

CLASS OF AQL: LEVEL II/ SINGLE SAMPLING
 MAJOR-0.65% MINOR – 1.5%

QUALITY STANDARD

DEFECT	CRITERIA	TYPE	FIGURE
SHORT CIRCUIT	-	MAJOR	-
MISSING SEGMENT	-	MAJOR	-
UNEVEN / POOR CONTRAST	-	MAJOR	-
CROSS TALK	-	MAJOR	-
PIN HOLE	$MAX(a,b) \leq 1 / 4 W$	MINOR	1
EXCESS SEGMENT	$MAX(c,d) \leq 1 / 4 T$	MINOR	1
BUBBLES	$d^* \geq 0.2$ QTY=0	MINOR	2
BLACKS SPOTS	$d \leq 0.3$ N.A.** $0.3 < d \leq 0.4$ QTY ≤ 1 $0.4 < d$ QTY=0	MINOR	2
LINE SCRATCHES	$x \geq 0.7$ $y \geq 0.05$ QTY=0	MINOR	3
BLACK LINE	$x \geq 0.7$ $y \geq 0.05$ QTY=0	MINOR	3

*d = MAX (d₁,d₂)

** N. A . = NOT APPLICABLE

DEFECT TABLE : B

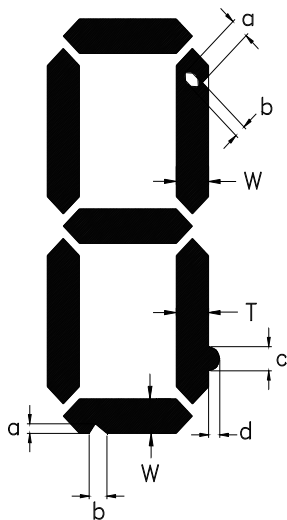
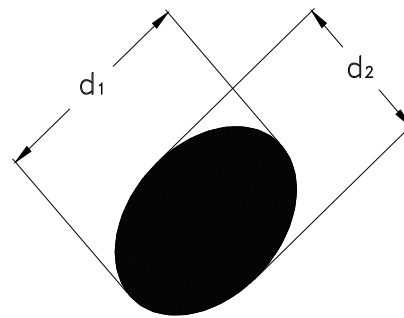
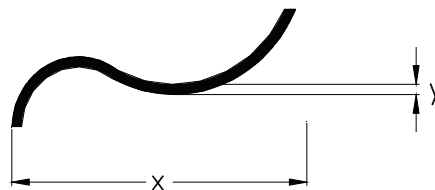

fig . 1



POLARIZER BUBBLES / SPOTS

fig . 2



LINE SCRATCHES / BLACK LINE

fig . 3

QUALITY STANDARD (CONT .)

DEFECT		CRITERIA	TYPE	FIGURE
CHIPS	CONTACT EDGE	$e \leq 1/2T$ $f \leq 1/3W$ $g \leq 3.5$	MINOR	4
	BOTTOM GLASS	$p \leq 1.0$ $q \leq 3.5$ $r \leq 1/2T$		4
	CORNER	$a \leq 1.5$ $b \leq W$		4
	TOP GLASS	$a \leq 3.0$ $b \leq 1/3T$ $c \leq 1/2W$		5
GLASS PROTRUSION		$a \leq 1/4 W$	MINOR	6
RAINBOW		-	MINOR	-

UNLESS STATE OTHERWISE , ALL UNIT ARE IN MILLIMETER .

DEFECT TABLE : B

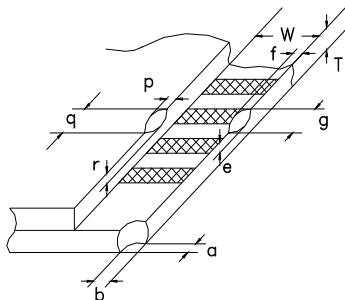

fig . 4

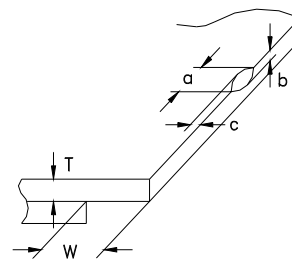

fig . 5

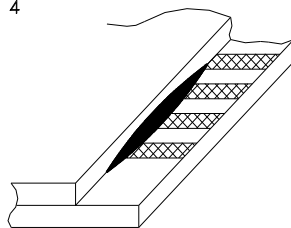

fig . 6

HANDLING PRECAUTIONS

(6) CAUTION OF LCD HANDLING & CLEANING

The polarizing plate on the surface of the panel is made from organic substances. Be very careful for chemicals not to touch the plate or it leads the polarizing plate to deteriorate.

If the use of a chemical is unavoidable, wipe the panel lightly with soft materials, such as gauze and absorbent cotton, soaked in a solvent.

*Usable solvent: Alcohol (ethanol, IPA and the like)

*Appropriate solvent: Ketones, ethyl alcohol

Avoid wiping with a dry cloth, since it could damage the surface of the polarizing plate and others.

Do not expose to direct sunlight or fluorescent light for a long time

(2) CAUTION AGAINST STATIC CHARGE

The LCD modules use CMOS LSI drivers, so customers are recommended that any unused input terminal would be connected to V_{DD} or V_{SS} , do not input any signals before power is turned on, and ground your body, work/assembly areas, assembly equipment to protect against static electricity.

(3) ESD PRECAUTION

Inputs and outputs are protected against electrostatic discharge in normal handling. However, to be totally safe, it is recommended to take normal precautions appropriate to handling LCM module. For example: product surface grounding. Always take ESD precaution when handling the *LCD Module*. Components are exposed for direct finger touches and can be damaged unless ESD precaution is taken.

(4) PACKAGING

Avoid intense shock and falls from a height and do not operate or store them exposed to direct sunshine or high temperature/humidity for long periods.

(5) CAUTION FOR OPERATION

The viewing angle can be adjusted by varying the LCD driving voltage V_O .

Driving voltage should be kept within specified range, excess voltage shortens display life.

Response time increases with decrease in temperature.

Display may turn black or dark Blue at temperature above its operational range; this is however not destructive and the display will return to normal once the temperature falls back to range.

Mechanical disturbance during operation (such as pressing on the viewing area) may cause the segments to appear "fractured". They will recover once the display is turned off.

Condensation at terminals will cause malfunction and possible electrochemical reaction. Relative humidity of the environment should therefore be kept below 60%.

(6) SAFETY

Liquid crystal may leak out of a damaged LCD, it is recommended to wash off the liquid crystal by using solvents such as acetone or ethanol and should be burned up later.

If any liquid leak out of a damaged glass cell comes in contact with your hands, wash it off with soap and water immediately.

WARRANTY

CLOVER will replace or repair any of her LCD module in accordance with her LCD specification for a period of one year from date of shipment. The warranty liability of Clover is limited to repair and/or replacement. Clover will not be responsible for any subsequent or consequential event.