



CLOVER DISPLAY LTD.

LCD MODULE SPECIFICATION

Model: CG9162F - _ _ - _ _ - _ _ - _ _

Revision	01
Engineering	Timmy Kwan
Date	25 Oct 2010
Our Reference	X9046

ADDRESS : 1st FLOOR, EFFICIENCY HOUSE, 35 TAI YAU STREET, SAN PO KONG,
KOWLOON, HONG KONG.

TEL : (852) 2341 3238 (SALES OFFICE) (852) 2342 8228 (GENERAL OFFICE)

FAX : (852) 2357 4237 (SALES OFFICE)

E-MAIL : cdl@cloverdisplay.com

URL : <http://www.cloverdisplay.com>

MODE OF DISPLAY**Display mode**

- TN positive
 TN negative
 STN : Yellow green
 Grey
 Blue (negative)
 FSTN positive
 FSTN negative

Display condition

- Reflective type
 Transflective type
 Transmissive type
 Others

Viewing direction

- 6 O' clock
 12 O' clock
 3 O' clock
 9 O' clock

LCD MODULE NUMBER NOTATION:

CV9162H- N N - S R - N 6 - T
 | | | | | | | |
 (1) (2) (3) (4) (5) (6) (7) (8)

*(1)---Model number of standard LCD Modules

*(2)---Backlight type

- N – No backlight
 E – EL backlight
 L – Side-lited LED backlight
 M– Array LED backlight
 C – CCFL

*(3)---Backlight color

- N – No backlight
 A – Amber
 B – Blue
 O– Orange
 W–White
 Y – Yellow green

*(4)---Display mode

- T – TN
 V – TN (Negative)
 S – STN Yellow green
 G – STN Grey
 B – STN Blue (Negative)
 F – FSTN
 N – FSTN (Negative)

*(5)---Rear polarizer type

- R – Reflective
 F – Transflective
 T – Transmissive

*(6)---Temperature range

- N – Normal
 W– Extended

*(7)---Viewing direction

- 6 – 6 O'clock
 2 – 12 O'clock
 3 – 3 O'clock
 9 – 9 O'clock

*(8)---Special code for other requirements
(Can be omitted if not used)

GENERAL DESCRIPTION

Display mode : 16 characters x 2 lines, COG LCD module
 Interface : 4 bit or 8 bit parallel
 Driving method : 1/16 duty, 1/5 bias
 Controller IC : Sunplus SPLC782A1 or equivalent
 For the detailed information, please refer to the IC specifications.

Item	Dimension	Unit	Item	Dimension	Unit
Outline Dimension		mm	Viewing Area	99.0(L)x24.0(W)	mm
No Backlight (N)	102.6(L) x 36.0(W) x 2.9MAX.(H)	mm	Dot Pitch	0.98(L)x1.16(W)	mm
LED Sided Backlight(L)	110.3(L) x 36.0(W) x 6.7MAX.(H)	mm	Dot Size	0.92(L)x1.1(W)	mm
Character Size	4.84 (L) x 9.66 (W)	mm	Character Pitch	6.0 (L)x10.34 (W)	mm

CONNECTOR PIN ASSIGNMENT

Pin No.	Signal	Function
1	DB7	DATA BUS
2	DB6	DATA BUS
3	DB5	DATA BUS
4	DB4	DATA BUS
5	DB3	DATA BUS
6	DB2	DATA BUS
7	DB1	DATA BUS
8	DB0	DATA BUS
9	E	ENABLE SIGNAL
10	RW	READ/WRITE SELECT
11	RS	REGISTER SELECT
12	VLCD	OPERATING VOLTAGE FOR LCD
13	VDD	SUPPLY VOLTAGE FOR LOGIC
14	VSS	GROUND
* 15	BL+	SUPPLY VOLTAGE FOR BACKLIGHT(+VE)
* 16	BL-	SUPPLY VOLTAGE FOR BACKLIGHT(-VE)

Note (*) : Pin 15, 16 are used for backlight version.

COUNTER DRAWING OF MODULE DIMENSION (WITH NO BACKLIGHT)

MARK	REASON	PREPARED	DATE
△	Change backlight dimension	Timmy	22 OCT 10
△			
△			
△			

No backlight version

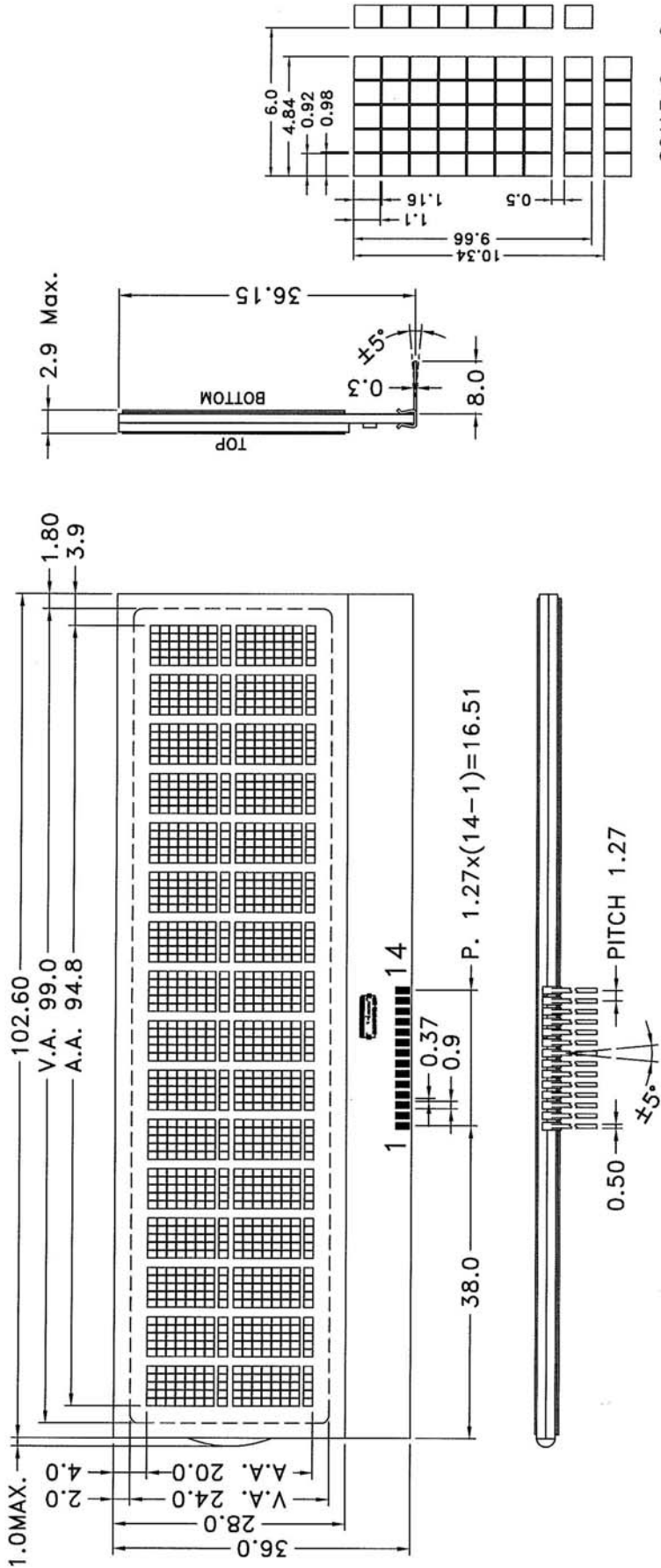

TOLERANCE IF NOT SPECIFY ±0.5mm		SCALE N.T.S.	UNIT IN mm	CLOVER DISPLAY LTD. (HK)		SHEET 1 OF 4	
REV.	REVISION RECORD		DATE	CUSTOMER	APPROVED	MODEL NO.	CG9162F
00	1st ISSUE		26 JUN 09	STANDARD		TITLE:	MODULE DIMENSION
01	Change backlight dimension		22 OCT 10	AGENT	APPROVED	DRAWN BY:	Ruifang
						DATE:	22 OCT 10
						CHECKED BY:	DATE: 22 OCT 10
						APPROVED BY:	DATE: 22 OCT 10
				CUSTOMER REF.	OUR REF. X9046		

COUNTER DRAWING OF MODULE DIMENSION (WITH SIDE BACKLIGHT)

Side backlight version

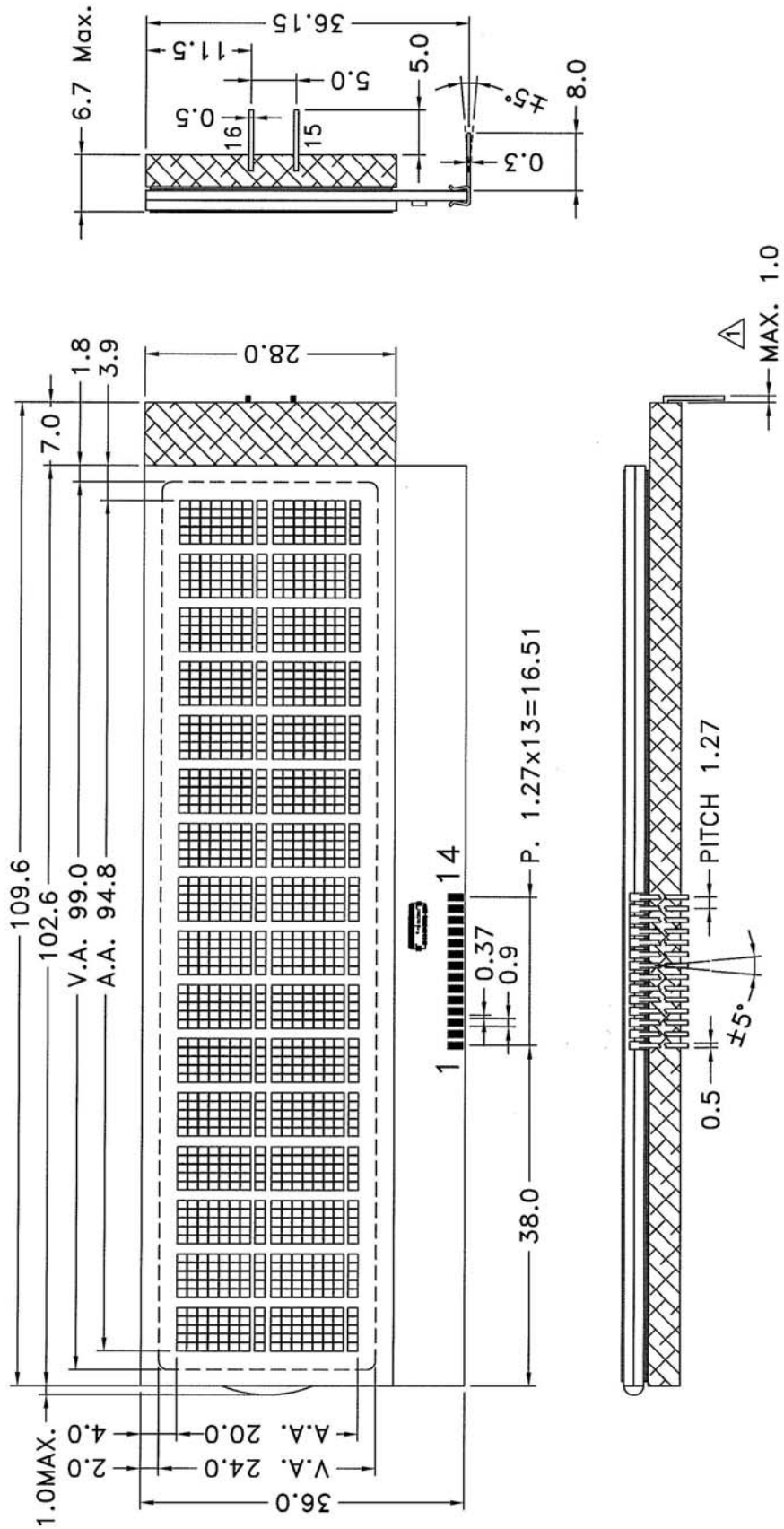

TOLERANCE IF NOT SPECIFY ±0.5mm		SCALE N.T.S.	UNIT IN mm	CLOVER DISPLAY LTD. (HK)		SHEET 2 OF 4
REV.	REVISION RECORD	DATE	CUSTOMER	APPROVED		MODEL NO. CG9162F
00	1st ISSUE	26 JUN 09	STANDARD	APPROVED		TITLE: MODULE DIMENSION
01	Change backlight dimension	22 OCT 10	AGENT	APPROVED		DRAWN BY: Ruifang DATE: 22 OCT 10
			CUSTOMER REF.	OUR REF. X9046		CHECKED BY: DATE: 22 OCT 10
						APPROVED BY: DATE: 22 OCT 10

COUNTER DRAWING OF PIN OUT & BLOCK DIAGRAM

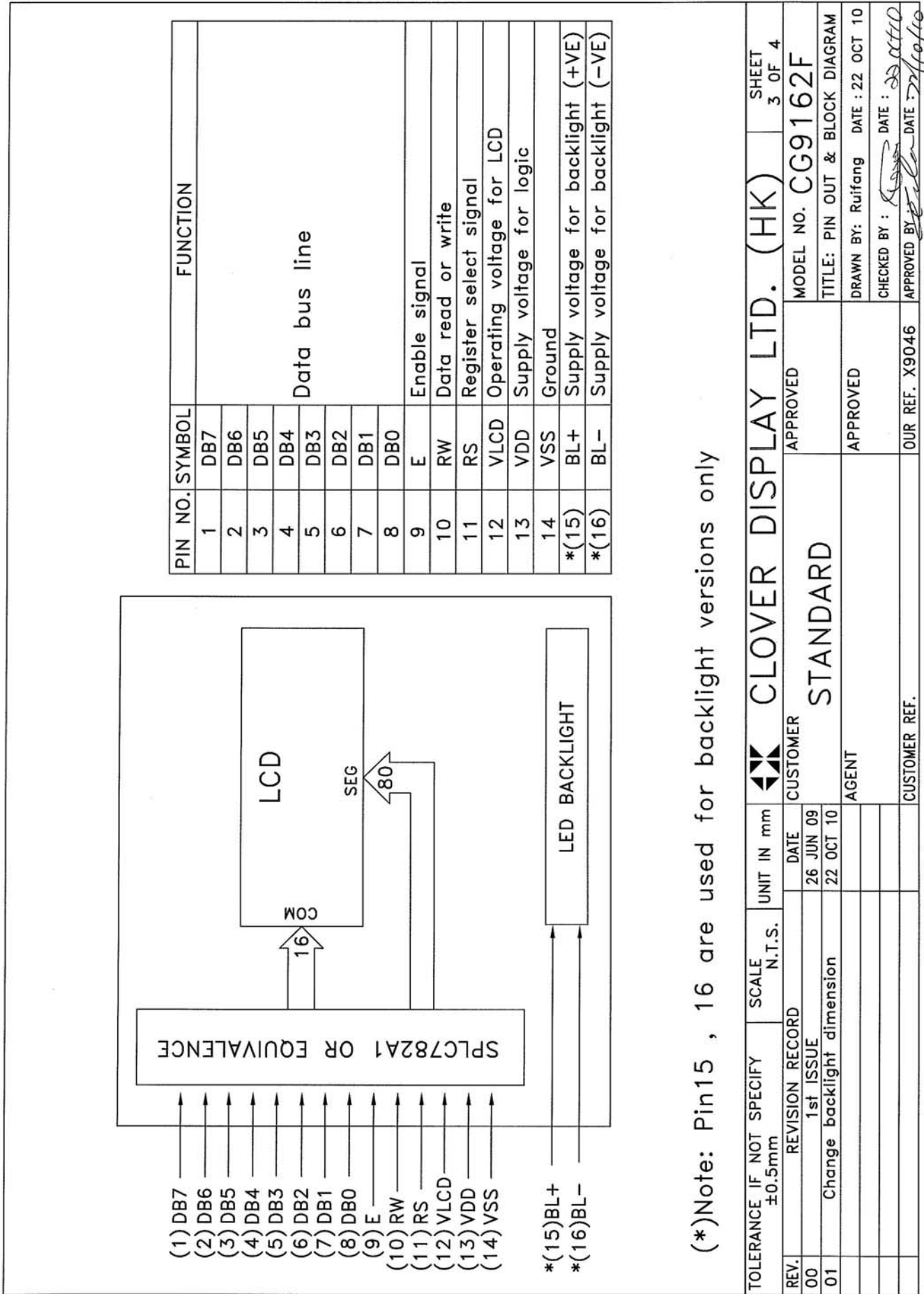

PIN NO.	SYMBOL	FUNCTION
1	DB7	Data bus line
2	DB6	
3	DB5	
4	DB4	
5	DB3	
6	DB2	
7	DB1	
8	DB0	
9	E	Enable signal
10	RW	Data read or write
11	RS	Register select signal
12	VLCD	Operating voltage for LCD
13	VDD	Supply voltage for logic
14	VSS	Ground
*(15)	BL+	Supply voltage for backlight (+VE)
*(16)	BL-	Supply voltage for backlight (-VE)

TOLERANCE IF NOT SPECIFY ±0.5mm		SCALE N.T.S.	UNIT IN mm	CLOVER DISPLAY LTD. (HK)		SHEET 3 OF 4
REV.	REVISION RECORD	DATE	CUSTOMER	APPROVED	MODEL NO.	CG9162F
00	1st ISSUE	26 JUN 09	STANDARD		TITLE:	PIN OUT & BLOCK DIAGRAM
01	Change backlight dimension	22 OCT 10	AGENT	APPROVED	DRAWN BY:	Ruifang DATE : 22 OCT 10
					CHECKED BY:	DATE : <i>22 Oct 10</i>
					APPROVED BY:	DATE : <i>22 Oct 10</i>
				OUR REF. X9046		
				CUSTOMER REF.		

ELECTRICAL CHARACTERISTICS

Conditions: VSS=0V, Ta=25°C

Item	Symbol	MIN.	TYP.	MAX.	Unit	Item	Symbol	MIN.	TYP.	MAX.	Unit
Supply Voltage for Logic	VDD	4.75	5.0	5.25	V	“H”Level Input Voltage	VIH	0.7VDD	—	VDD	V
Supply Current for Logic	IDD	—	0.18	0.27	mA	“L”Level Input Voltage	VIL	-0.3	—	0.55	V
Operating Voltage for LCD(*)	VLCD	4.3	4.5	4.7	V	—	—	—	—	—	—

Note (*): There is tolerance in optimum LCD driving voltage during production and it will be within the specified range.

Side Backlight:

Constant voltage driving

Item	Symbol	MIN.	TYP.	MAX.	Unit	Condition
White Backlight current	IBL	25	30	35	mA	VBL=3.6V

ABSOLUTE MAXIMUM RATINGS

Please make sure not to exceed the following maximum rating values under the worst application conditions

Item	Symbol	Rating (for normal temperature)	Rating (for wide temperature)	Unit
Supply Voltage	VDD	-0.3 to 7.0	-0.3 to 7.0	V
Input Voltage	VIN	-0.3 to VDD+0.3	-0.3 to VDD+0.3	V
Operating Temperature	Topr	0 to 50	-20 to 70	°C
Storage Temperature	Tstg	-10 to 60	-30 to 80	°C

INSTRUCTION TABLE

Instruction	Instruction Code										Description	Max. Execution time (Temp = -20°C ~ +75°C)
	RS	R/W	DB7	DB6	DB5	DB4	DB3	DB2	DB1	DB0		
Clear Display	0	0	0	0	0	0	0	0	0	1	Write "20H" to DDRAM and set DDRAM address to "00H" from AC	4.1ms
Return Home	0	0	0	0	0	0	0	0	1	-	Set DDRAM address to "00H" from AC and return cursor to its original position if shifted. The contents of DDRAM are not changed.	4.1ms
Entry Mode Set	0	0	0	0	0	0	0	1	I/D	S	Assign cursor moving direction and enable the shift of entire display	100µs
Display ON/OFF Control	0	0	0	0	0	0	1	D	C	B	Set display (D), cursor(C), and blinking of cursor(B) on/off control bit.	100µs
Cursor or Display Shift	0	0	0	0	0	1	S/C	R/L	-	-	Set cursor moving and display shift control bit, and the direction, without changing of DDRAM data.	100µs
Function Set	0	0	0	0	1	DL	N	F	-	-	Set interface data length (DL: 8-bit/4-bit), numbers of display line (N: 2-line/1-line) and, display font type (F:5x10 dots/5x8 dots)	100µs
Set CGRAM Address	0	0	0	1	AC5	AC4	AC3	AC2	AC1	AC0	Set CGRAM address in address counter.	100µs
Set DDRAM Address	0	0	1	AC6	AC5	AC4	AC3	AC2	AC1	AC0	Set DDRAM address in address counter	100µs
Read Busy Flag and Address Counter	0	1	BF	AC6	AC5	AC4	AC3	AC2	AC1	AC0	Whether during internal operation or not can be known by reading BF. The contents of address counter can also be read.	0µs
Write Data to RAM	1	0	D7	D6	D5	D4	D3	D2	D1	D0	Write data into internal RAM (DDRAM/CGRAM).	100µs
Read Data from RAM	1	1	D7	D6	D5	D4	D3	D2	D1	D0	Read data from internal RAM (DDRAM/CGRAM).	100µs

Figure 6-16: Instruction Table

Note: "-" don't care

DISPLAY DATA RAM (DD RAM) AND CHARACTER POSITION

16x2, 1/16 Duty Cycle

	1	2													16	DISPLAY POSITION
line 1	00	01													0F	DD RAM ADDRESS
line 2	40	41													4F	

AC CHARACTERISTICS

Write mode (Writing data from MPU to SPLC782A1)

Characteristics	Symbol	Limit			Unit	Test Condition
		Min.	Typ.	Max.		
E Cycle Time	t_C	500	-	-	ns	Pin E
E Pulse Width	t_{PW}	230	-	-	ns	Pin E
E Rise/Fall Time	t_R, t_F	-	-	20	ns	Pin E
Address Setup Time	t_{SP1}	40	-	-	ns	Pins: RS, R/W, E
Address Hold Time	t_{HD1}	10	-	-	ns	Pins: RS, R/W, E
Data Setup Time	t_{SP2}	80	-	-	ns	Pins: DB0 - DB7
Data Hold Time	t_{HD2}	10	-	-	ns	Pins: DB0 - DB7

Read mode (Reading Data from SPLC782A1 to MPU)

Characteristics	Symbol	Limit			Unit	Test Condition
		Min.	Typ.	Max.		
E Cycle Time	t_C	500	-	-	ns	Pin E
E Pulse Width	t_W	230	-	-	ns	Pin E
E Rise/Fall Time	t_R, t_F	-	-	20	ns	Pin E
Address Setup Time	t_{SP1}	40	-	-	ns	Pins: RS, R/W, E
Address Hold Time	t_{HD1}	10	-	-	ns	Pins: RS, R/W, E
Data Output Delay Time	t_D	-	-	160	ns	Pins: DB0 - DB7
Data hold time	t_{HD2}	5.0	-	-	ns	Pins: DB0 - DB7

Write Mode Timing Diagram (Writing Data from MPU to SPLC782A1)

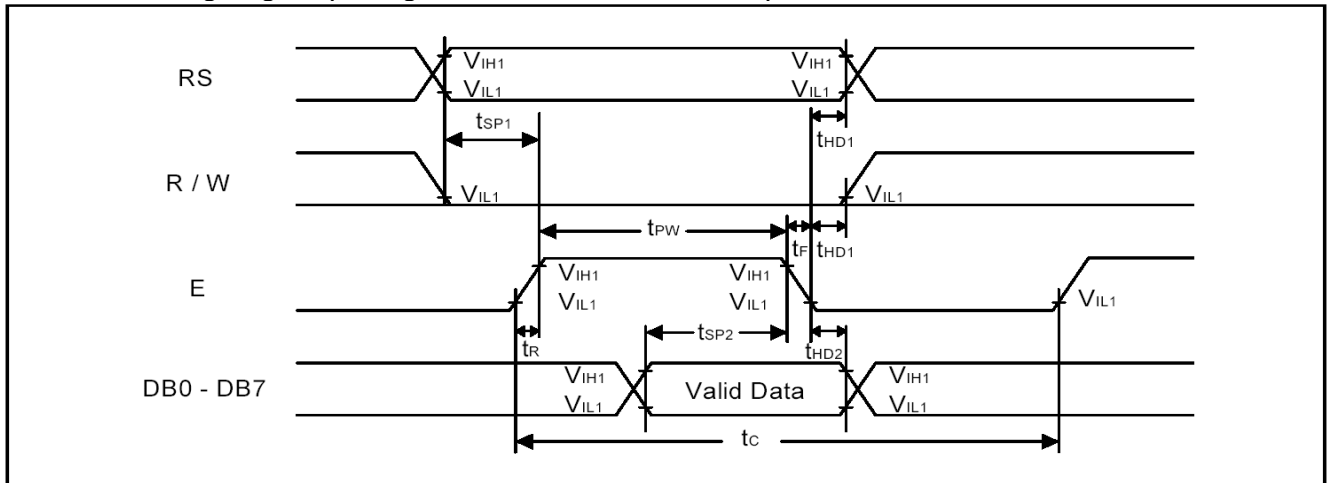

Read Mode Timing Diagram (Reading Data from SPLC782A1 to MPU)

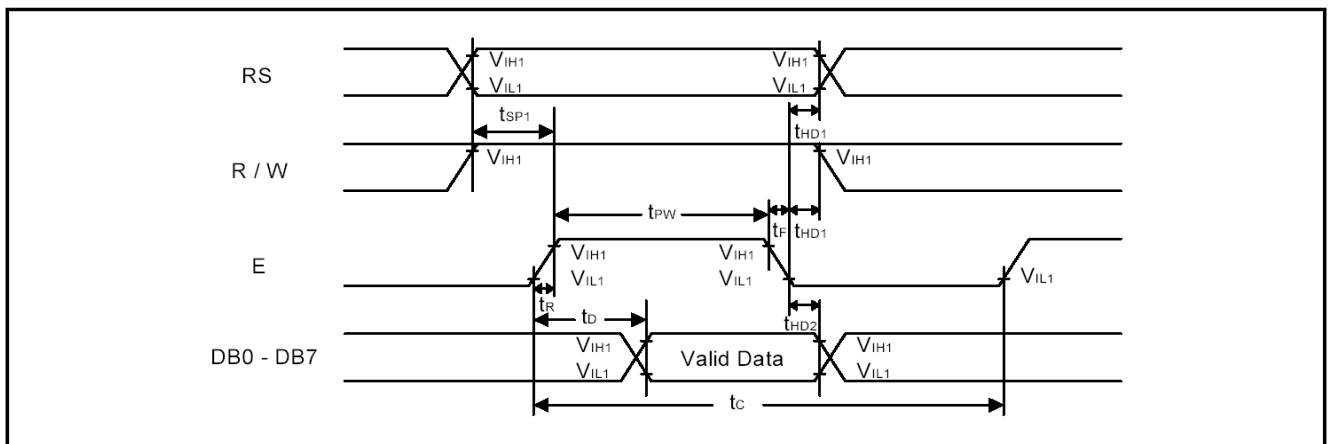

INITIALIZATION FLOWCHART

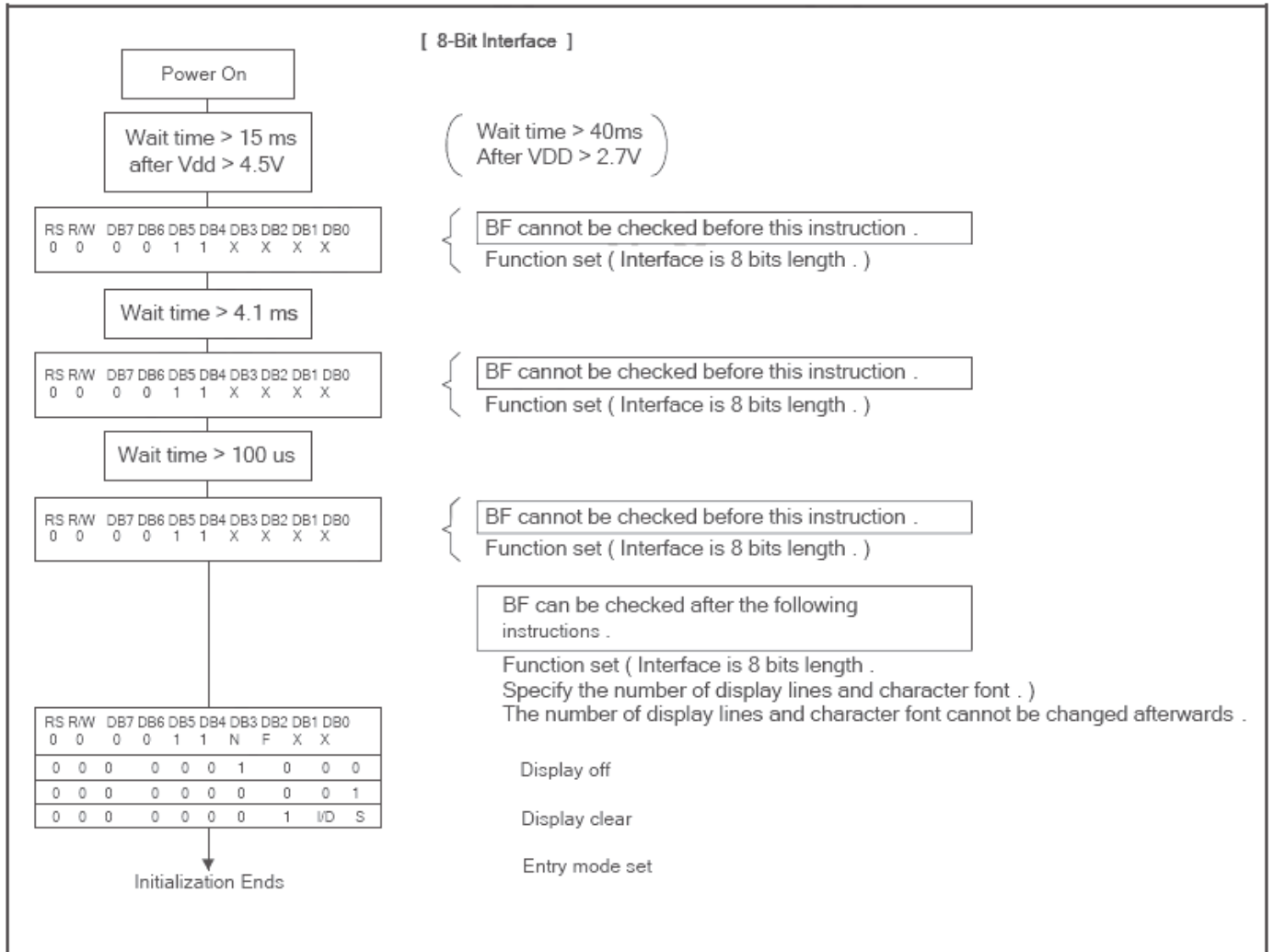

ELECTRO-OPTICAL CHARACTERISTICS

MEASURING CONDITION: POWER SUPPLY = V_{OP} / 64 Hz
 TEMPERATURE = 23 ± 5 °C
 RELATIVE HUMIDITY = 60 ± 20 %

ITEM	SYMBOL	UNIT	TYP. TN	TYP. STN
RESPONSE TIME	T _{on}	ms	130	150
	T _{off}	ms	170	190
CONTRAST RATIO	Cr	-	8	15
VIEWING ANGLE (6 O'clock) Cr ≥ 2	V _{3:00}	°	70	45
	V _{6:00}	°	45	70
	V _{9:00}	°	70	45
	V _{12:00}	°	5	60

THE ELECTRO-OPTICAL CHARACTERISTICS ARE MEASURED VALUE BUT NOT GUARANTEED ONES.

RELIABILITY OF LCD MODULE

ITEM	TEST CONDITION FOR NORMAL TEMPERATURE	TEST CONDITION FOR WIDE TEMPERATURE	TIME
High temperature operating	50°C	70°C	240 hours
Low temperature operating	0°C	-20°C	240 hours
High temperature storage	60°C	80°C	240 hours
Low temperature storage	-10°C	-30°C	240 hours
Temperature-humidity storage	40°C 90% R.H.	60°C 90% R.H.	96 hours
Temperature cycling	-10°C to 60°C 30 Min Dwell	-30°C to 80°C 30 Min Dwell	5 cycle
Vibration Test at LCM Level	Freq 10-55 Hz Sweep rate: 10-55-10 at 1 min Sweep mode Linear Displacement: 2 mm p-p 1 Hour each for X, Y, Z	Freq 10-55 Hz Sweep rate: 10-55-10 at 1 min Sweep mode Linear Displacement: 2 mm p-p 1 Hour each for X, Y, Z	—

SAMPLING METHOD

SAMPLING PLAN: MIL-STD 105E

CLASS OF AQL: LEVEL II/ SINGLE SAMPLING
MAJOR-0.65% MINOR – 1.5%

QUALITY STANDARD

DEFECT	CRITERIA	TYPE	FIGURE
SHORT CIRCUIT	-	MAJOR	-
MISSING SEGMENT	-	MAJOR	-
UNEVEN / POOR CONTRAST	-	MAJOR	-
CROSS TALK	-	MAJOR	-
PIN HOLE	$\text{MAX}(a,b) \leq 1/4 W$	MINOR	1
EXCESS SEGMENT	$\text{MAX}(c,d) \leq 1/4 T$	MINOR	1
BUBBLES	$d^* \geq 0.2$ QTY=0	MINOR	2
BLACKS SPOTS	$d \leq 0.3$ N.A.** $0.3 < d \leq 0.4$ QTY \leq 1 $0.4 < d$ QTY=0	MINOR	2
LINE SCRATCHES	$x \geq 0.7$ $y \geq 0.05$ QTY=0	MINOR	3
BLACK LINE	$x \geq 0.7$ $y \geq 0.05$ QTY=0	MINOR	3

*d = MAX (d₁,d₂)

** N. A . = NOT APPLICABLE

DEFECT TABLE : B

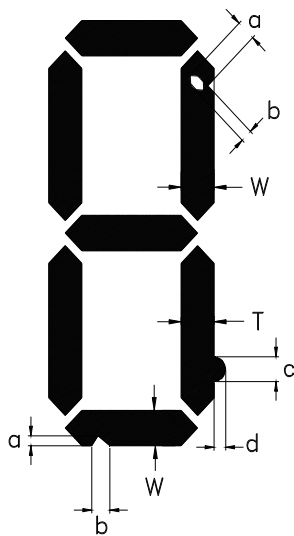
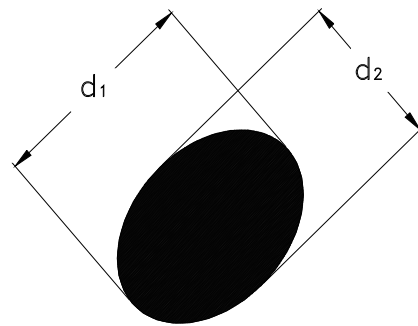
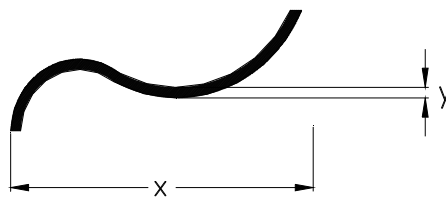

fig . 1



POLARIZER BUBBLES / SPOTS

fig . 2



LINE SCRATCHES / BLACK LINE

fig . 3

QUALITY STANDARD (CONT .)

DEFECT		CRITERIA	TYPE	FIGURE
CHIPS	CONTACT EDGE	$e \leq 1/2T$ $f \leq 1/3W$ $g \leq 3.5$	MINOR	4
	BOTTOM GLASS	$p \leq 1.0$ $q \leq 3.5$ $r \leq 1/2T$		4
	CORNER	$a \leq 1.5$ $b \leq W$		4
	TOP GLASS	$a \leq 3.0$ $b \leq 1/3T$ $c \leq 1/2W$		5
GLASS PROTRUSION		$a \leq 1/4 W$	MINOR	6
RAINBOW		-	MINOR	-

UNLESS STATE OTHERWISE , ALL UNIT ARE IN MILLIMETER .

DEFECT TABLE : B

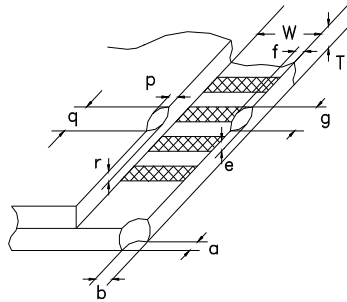

fig . 4

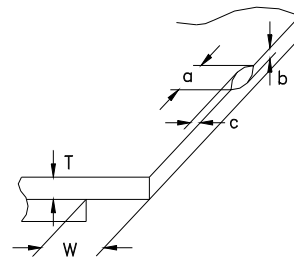

fig . 5

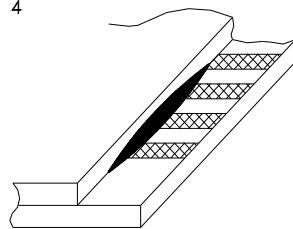

fig . 6

HANDLING PRECAUTIONS

(1) CAUTION OF LCD HANDLING & CLEANING

The polarizing plate on the surface of the panel is made from organic substances. Be very careful for chemicals not to touch the plate or it leads the polarizing plate to deteriorate.

If the use of a chemical is unavoidable, wipe the panel lightly with soft materials, such as gauze and absorbent cotton, soaked in a solvent.

*Usable solvent: Alcohol (ethanol, IPA and the like)

*Appropriate solvent: Ketones, ethyl alcohol

Avoid wiping with a dry cloth, since it could damage the surface of the polarizing plate and others.

Do not expose to direct sunlight or fluorescent light for a long time

(2) CAUTION AGAINST STATIC CHARGE

The LCD modules use CMOS LSI drivers, so customers are recommended that any unused input terminal would be connected to V_{DD} or V_{SS} , do not input any signals before power is turned on, and ground your body, work/assembly areas, assembly equipment to protect against static electricity.

(3) ESD PRECAUTION

Inputs and outputs are protected against electrostatic discharge in normal handling. However, to be totally safe, it is recommended to take normal precautions appropriate to handling LCM module. For example: product surface grounding. Always take ESD precaution when handling the *LCD Module*. Components are exposed for direct finger touches and can be damaged unless ESD precaution is taken.

(4) PACKAGING

Avoid intense shock and falls from a height and do not operate or store them exposed to direct sunshine or high temperature/humidity for long periods.

(5) CAUTION FOR OPERATION

The viewing angle can be adjusted by varying the LCD driving voltage V_O .

Driving voltage should be kept within specified range, excess voltage shortens display life.

Response time increases with decrease in temperature.

Display may turn black or dark Blue at temperature above its operational range; this is however not destructive and the display will return to normal once the temperature falls back to range.

Mechanical disturbance during operation (such as pressing on the viewing area) may cause the segments to appear "fractured". They will recover once the display is turned off.

Condensation at terminals will cause malfunction and possible electrochemical reaction. Relative humidity of the environment should therefore be kept below 60%.

(6) SAFETY

Liquid crystal may leak out of a damaged LCD, it is recommended to wash off the liquid crystal by using solvents such as acetone or ethanol and should be burned up later.

If any liquid leak out of a damaged glass cell comes in contact with your hands, wash it off with soap and water immediately.

WARRANTY

CLOVER will replace or repair any of her LCD module in accordance with her LCD specification for a period of one year from date of shipment. The warranty liability of Clover is limited to repair and/or replacement. Clover will not be responsible for any subsequent or consequential event.