



CLOVER DISPLAY LTD.

## LCD MODULE SPECIFICATION

**Model: CG12864B - \_ \_ - \_ \_ - \_ \_ - \_ \_**

Revision	00
Engineering	Longson Yeung
Date	03 June 2009
Our Reference	X9042

ADDRESS : ROOM 1006, 10/F WESTIN CENTRE, 26 HUNG TO ROAD, KWUN TONG,  
KOWLOON, HONG KONG.

TEL : (852) 2341 3238 (SALES OFFICE) (852) 2342 8228 (GENERAL OFFICE)

FAX : (852) 2357 4237 (SALES OFFICE) (852) 2341 8785 (GENERAL OFFICE)

E-MAIL : [cdl@cloverdisplay.com](mailto:cdl@cloverdisplay.com)

URL : <http://www.cloverdisplay.com>

**MODE OF DISPLAY**

Display mode	Display condition	Viewing direction
STN : Yellow green	Reflective type	6 O' clock
Grey	Transflective type	12 O' clock
Blue (negative)	Transmissive type	3 O' clock
FSTN positive	Others	9 O' clock
FSTN negative		

**LCD MODULE NUMBER NOTATION:**

CG12864B- N N - S R - N 6 - T

| | | | | | | |  
 (1) (2) (3) (4) (5) (6) (7) (8)

\*(1)---Model number of standard LCD Modules

\*(2)---Backlight type

N – No backlight  
 E – EL backlight  
 L – Side-lited LED backlight  
 M– Array LED backlight  
 C – CCFL

\*(3)---Backlight color

N – No backlight  
 A – Amber  
 B – Blue  
 O– Orange  
 W–White  
 Y – Yellow green

\*(4)---Display mode

T – TN  
 V – TN (Negative)  
 S – STN Yellow green  
 G – STN Grey  
 B – STN Blue (Negative)  
 F – FSTN  
 N – FSTN (Negative)

\*(5)---Rear polarizer type

R – Reflective  
 F – Transflective  
 T – Transmissive

\*(6)---Temperature range

N – Normal  
 W– Extended

\*(7)---Viewing direction

6 – 6 O'clock  
 2 – 12 O'clock  
 3 – 3 O'clock  
 9 – 9 O'clock

\*(8)---Special code for other requirements  
 (Can be omitted if not used)

**GENERAL DESCRIPTION**

Display mode	:	128 X 64 dots, graphic COG LCD module
Interface	:	Parallel/serial
Driving method	:	1/65 duty, 1/9 bias
Controller IC	:	Sitronix ST7565P or equivalent For the detailed information, please refer to the IC specifications.

**MECHANICAL DIMENSIONS**

Item	Dimension	Unit	Item	Dimension	Unit
Outline Dimension			Dot Pitch	0.52(L)x0.52(W)	mm
No backlight	77.0(L) x50.6 (W) x2.9 (H)(MAX)	mm	Dot Size	0.49(L)x0.49(W)	mm
LED side-lited backlight	78.4(L) x53.0 (W) x 7.0(H)	mm	Viewing Area	70.6(L)x38.6(W)	mm

**CONNECTOR PIN ASSIGNMENT**

Pin No.	Symbol	Function	Pin No.	Symbol	Function
1	NC	No connection	18	D7 (SDA)	Data bus (serial data input)
2	NC	No connection	19	D6 (SCL)	Data bus (serial clock input)
3	P/S	Parallel / serial data input select	20	D5	Data bus
4	C86	Mode select	21	D4	
5	V0	Power supply for LCD	22	D3	
6	V1		23	D2	
7	V2		24	D1	
8	V3		25	D0	
9	V4		26	RD (EN)	Read signal(enable input signal for 6800 mode)
10	CAP2N	Voltage converter	27	WR(R/W)	Write signal(read/write signal for 6800mode)
11	CAP2P		28	A0	Control instruction
12	CAP1P		29	RES	Reset
13	CAP1N		30	CS1	Chip select
14	CAP3P		31	NC	No connection
15	VOUT		32	NC	No connection
16	VSS	Ground	*33	A	Supply voltage for backlight(+VE)
17	VDD	Supply voltage for logic	*34	K	Supply voltage for backlight(-VE)

Note (\*): Pin 33, 34 are used for backlight version



COUNTER DRAWING OF PIN OUT & BLOCK DIAGRAM

PIN NO.	SYMBOL	FUNCTION
1	NC	No connection
2	NC	No connection
3	P/S	Parallel / serial data input select
4	C86	Mode select
5	V0	Power supply for LCD
6	V1	
7	V2	
8	V3	
9	V4	Voltage converter
10	CAP2N	
11	CAP2P	
12	CAP1P	
13	CAP1N	Ground
14	CAP3P	
15	VOUT	
16	VSS	Supply voltage for logic
17	VDD	
18	D7(SDA)	Data bus(serial data input)
19	D6(SCL)	Data bus(serial clock input)
20	D5	Data bus
21	D4	
22	D3	
23	D2	
24	D1	Read signal(enable input signal for 6800 mode)
25	D0	
26	RD(EN)	Write signal(read/write signal for 6800 mode)
27	WR(R/W)	
28	A0	Control instruction
29	RES	Reset
30	CS1	Chip select
31	NC	No connection
32	NC	No connection
*33	A	Supply voltage for backlight(+VE)
*34	K	Supply voltage for backlight(-VE)

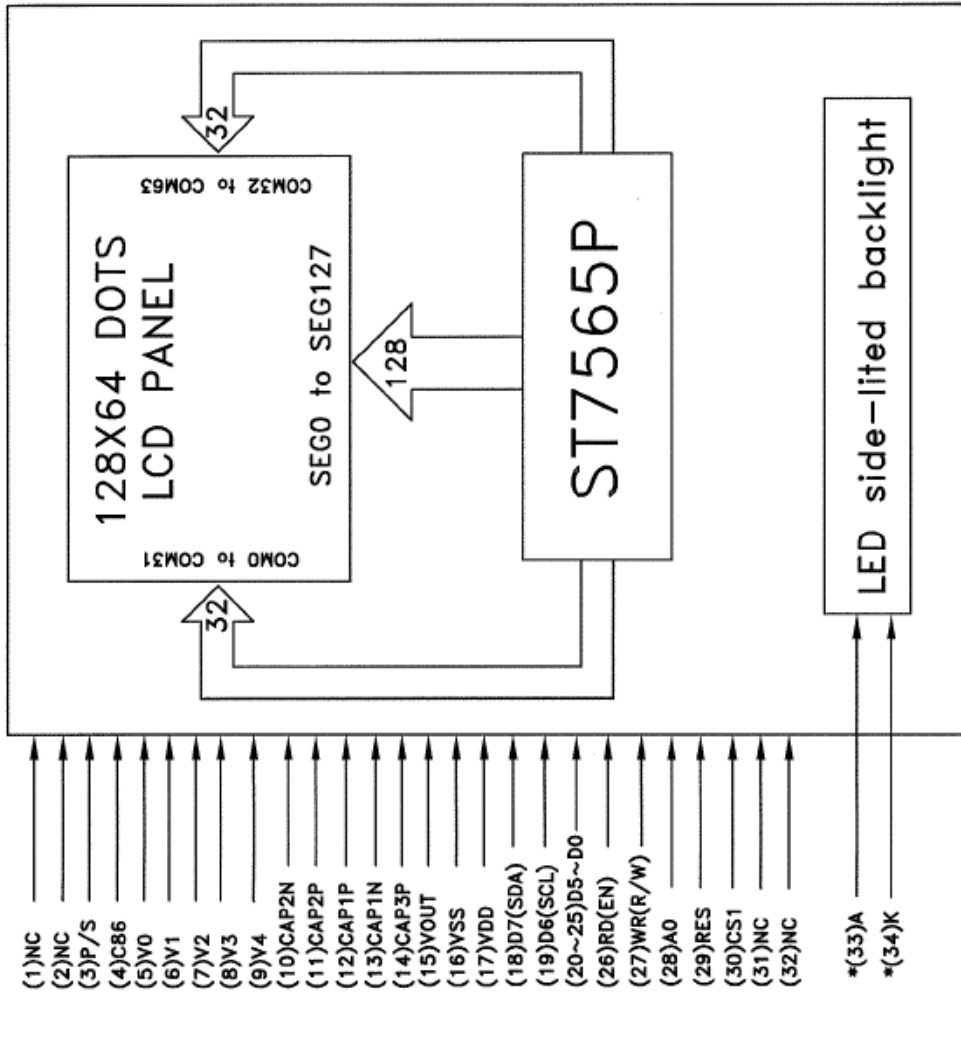

TOLERANCE IF NOT SPECIFY ±0.5mm	REVISION RECORD 1st ISSUE	SCALE N.T.S.	UNIT IN mm	CUSTOMER STANDARD	APPROVED	MODEL NO. CG12864B	SHEET 2 OF 3
REV. 00	DATE 01 JUN 09			AGENT	APPROVED	TITLE: PIN OUT & BLOCK DIAGRAM	
						DRAWN BY: MEN	DATE: 01 JUN 09
						CHECKED BY: <i>[Signature]</i>	DATE: 02 JUN 09
						APPROVED BY: <i>[Signature]</i>	DATE: 26/09
				CUSTOMER REF.	OUR REF. X9042		

**ELECTRICAL CHARACTERISTICS**

Conditions: VSS=0V, Ta=25

Item	Symbol	MIN.	TYP.	MAX.	Unit	Item	Symbol	MIN.	TYP.	MAX.	Unit
Supply Voltage for Logic	VDD	3.05	3.3	3.55	V	“H”Level Input Voltage	VIH	0.8VDD	-	VDD	V
Supply Current for Logic	IDD	-	0.23	0.34	mA	“L”Level Input Voltage	VIL	VSS	-	0.2VDD	V
Operating voltage for LCD	VLCD	8.8	9.0	9.2	V	-	-	-	-	-	-
<b>Side-lited LED Backlight Forward Voltage (VF)(*)</b>						<b>Side-lited LED Backlight Forward Current (IF)</b>					
White(*)	VBL	3.05	3.3	3.55	V	White	IBL	-	40	60	mA
Blue(*)	VBL	3.05	3.3	3.55	V	Blue	IBL	-	40	60	mA

(\*)To meet the optimum brightness, the backlight should be driven by constant voltage 3.3V.

**ABSOLUTE MAXIMUM RATINGS**

Please make sure not to exceed the following maximum rating values under the worst application conditions

Item	Symbol	Rating (for normal temperature)	Rating (for wide temperature)	Unit
Supply Voltage	VDD	-0.3 to +3.6	-0.3 to +3.6	V
Input Voltage	VT	-0.3 to VDD +0.3	-0.3 to VDD +0.3	V
Operating Temperature	Topr	0 to 50	-20 to 70	
Storage Temperature	Tstg	-10 to 60	-30 to 80	

**REFERENCE CIRCUIT EXAMPLE**

4x boosting circuit.

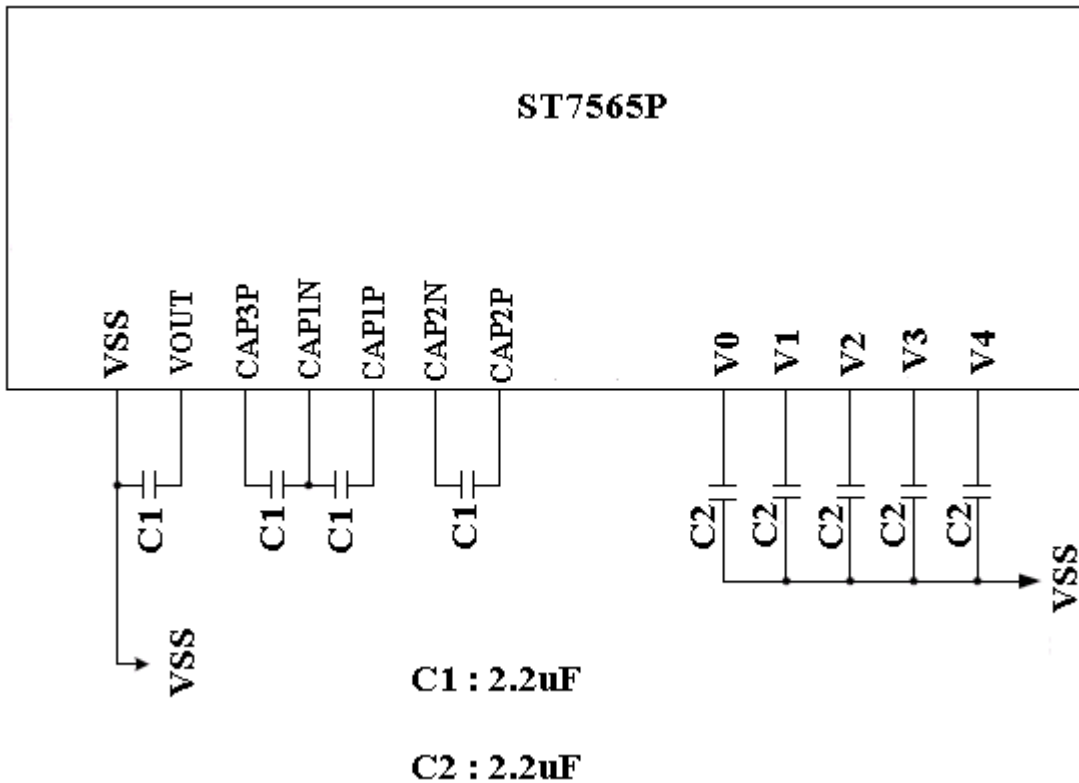

## INSTRUCTIONS TABLE

(Note) \*: disabled data

Command	Command Code										Function	
	A0	/RD	/WR	D7	D6	D5	D4	D3	D2	D1		D0
(1) Display ON/OFF	0	1	0	1	0	1	0	1	1	1	0	LCD display ON/OFF 0: OFF, 1: ON
(2) Display start line set	0	1	0	0	1	Display start address					Sets the display RAM display start line address	
(3) Page address set	0	1	0	1	0	1	1	Page address				Sets the display RAM page address
(4) Column address set upper bit	0	1	0	0	0	0	1	Most significant column address				Sets the most significant 4 bits of the display RAM column address.
Column address set lower bit	0	1	0	0	0	0	0	Least significant column address				Sets the least significant 4 bits of the display RAM column address.
(5) Status read	0	0	1	Status				0	0	0	0	Reads the status data
(6) Display data write	1	1	0	Write data							Writes to the display RAM	
(7) Display data read	1	0	1	Read data							Reads from the display RAM	
(8) ADC select	0	1	0	1	0	1	0	0	0	0	0	Sets the display RAM address SEG output correspondence 0: normal, 1: reverse
(9) Display normal/reverse	0	1	0	1	0	1	0	0	1	1	0	Sets the LCD display normal/reverse 0: normal, 1: reverse
(10) Display all points ON/OFF	0	1	0	1	0	1	0	0	1	0	0	Display all points 0: normal display 1: all points ON
(11) LCD bias set	0	1	0	1	0	1	0	0	0	1	0	Sets the LCD drive voltage bias ratio 0: 1/9 bias, 1: 1/7 bias (ST7565P)
(12) Read/modify/write	0	1	0	1	1	1	0	0	0	0	0	Column address increment At write: +1 At read: 0
(13) End	0	1	0	1	1	1	0	1	1	1	0	Clear read/modify/write
(14) Reset	0	1	0	1	1	1	0	0	0	1	0	Internal reset
(15) Common output mode select	0	1	0	1	1	0	0	0	0	*	*	Select COM output scan direction 0: normal direction 1: reverse direction
(16) Power control set	0	1	0	0	0	1	0	1	Operating mode		Select internal power supply operating mode	
(17) Vo voltage regulator internal resistor ratio set	0	1	0	0	0	1	0	0	Resistor ratio		Select internal resistor ratio(Rb/Ra) mode	
(18) Electronic volume mode set Electronic volume register set	0	1	0	1	0	0	0	0	0	0	1	Set the Vo output voltage electronic volume register
(20) Booster ratio set	0	1	0	1	1	1	1	1	0	0	0	select booster ratio 00: 2x,3x,4x 01: 5x 11: 6x
(21) Power saver												Display OFF and display all points ON compound command
(22) NOP	0	1	0	1	1	1	0	0	0	1	1	Command for non-operation
(23) Test	0	1	0	1	1	1	1	*	*	*	*	Command for IC test. Do not use this command

**RECOMMENDED INITIAL SETTINGS**

Display Start Line Set : 40H

ADC Select : A0H

LCD Bias Set : A2H

Common Output Mode Select : C0H

Power Control Set: 2FH

V0 Voltage Regulator Internal Resistor Ratio Set : 26H

Electronic Volume Register Set : 12H

Booster Ratio Set : 00H

**DISPLAY DATA RAM**

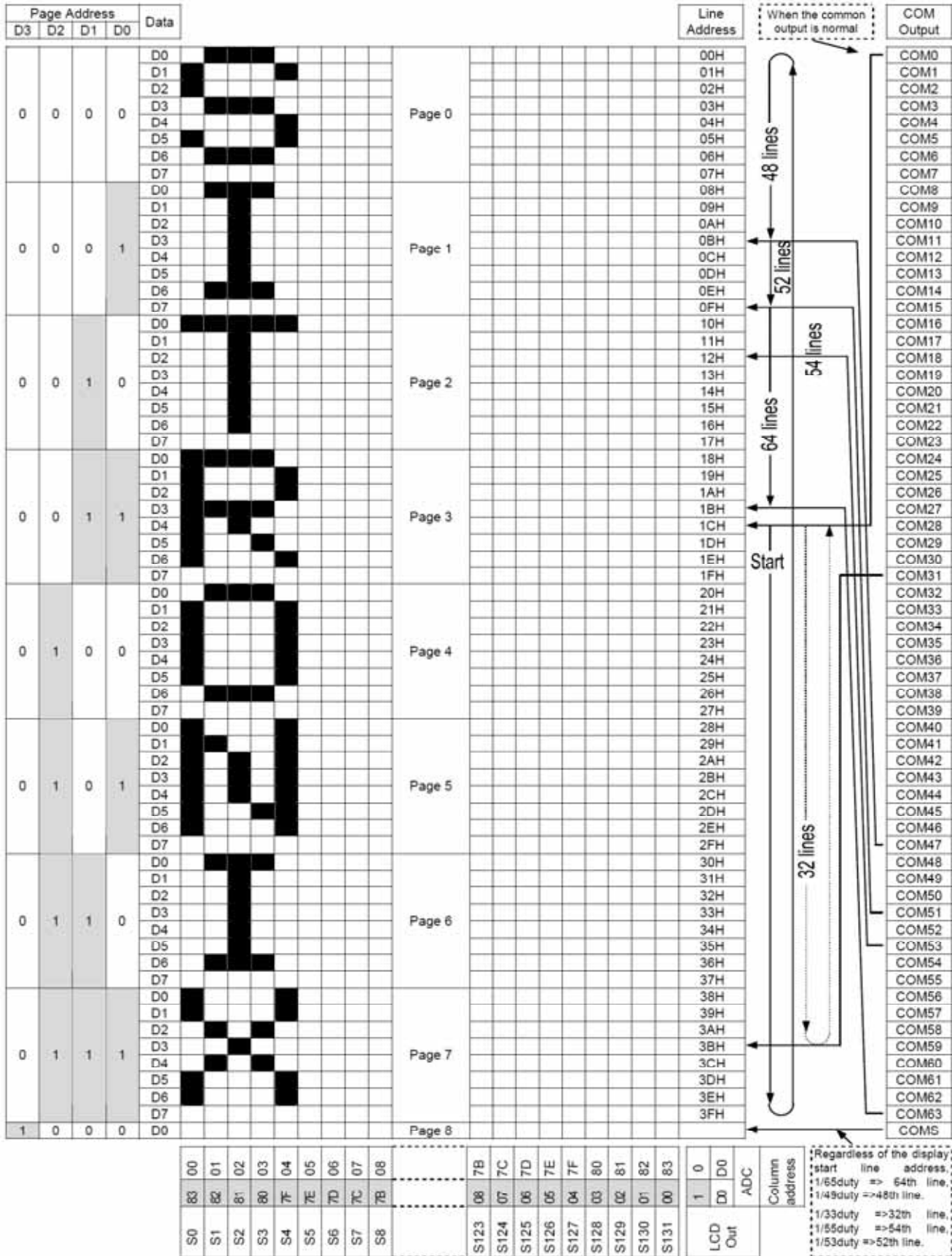

PARALLEL INTERFACE TIMING DIAGRAM (8080 MODE)

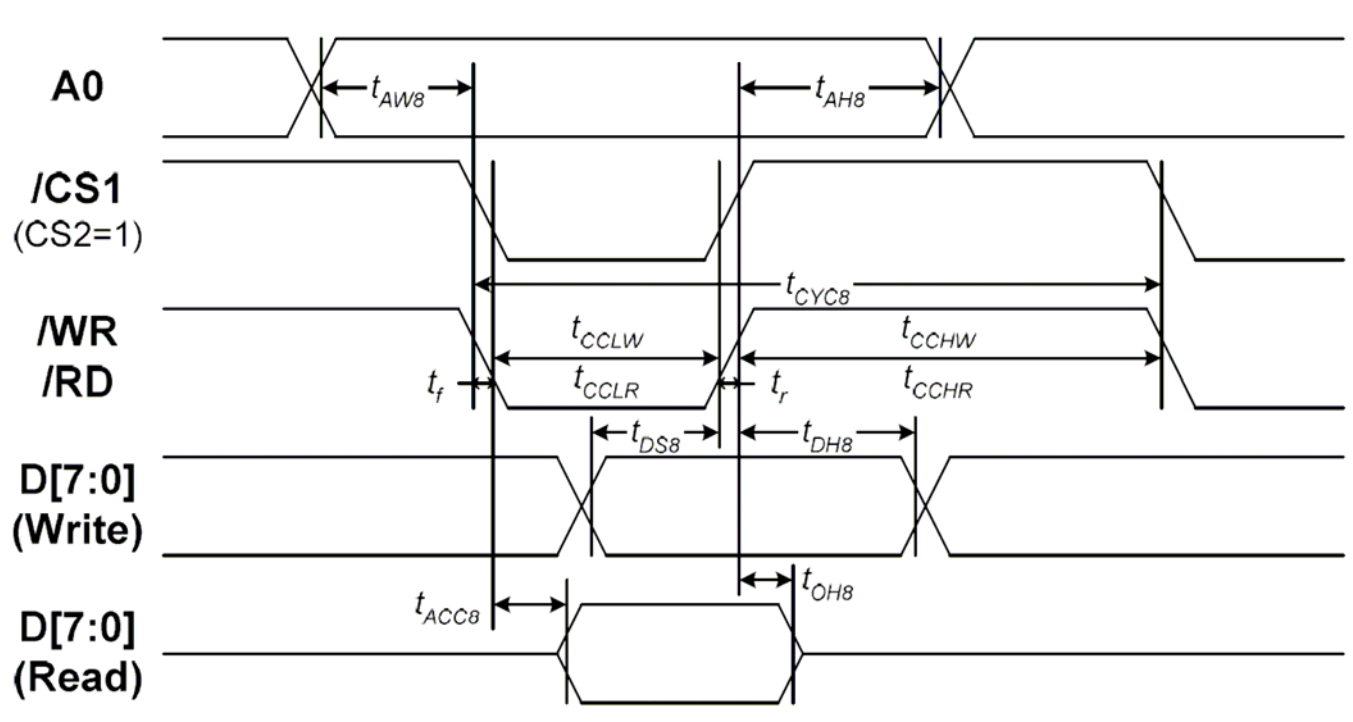

**PARALLEL INTERFACE TIMING CHARACTERISTICS (8080 MODE)**

(VDD = 3.3V, Ta = -30 to 85°C)

Item	Signal	Symbol	Condition	Rating		Units
				Min.	Max.	
Address hold time	A0	t <sub>AH8</sub>		0	—	Ns
Address setup time		t <sub>AW8</sub>		0	—	
System cycle time		t <sub>CYC8</sub>		240	—	
Write L pulse width	/WR	t <sub>CCLW</sub>		80	—	
Write H pulse width		t <sub>CCHW</sub>		80	—	
Read L pulse width	/RD	t <sub>CCLR</sub>		140	—	
Read H pulse width		t <sub>CCHR</sub>		80	—	
Write Data setup time	D0 to D7	t <sub>DS8</sub>		40	—	
Write Address hold time		t <sub>DH8</sub>		0	—	
Read access time		t <sub>ACC8</sub>	CL = 100 pF	—	70	
Read Output disable time		t <sub>OH8</sub>	CL = 100 pF	5	50	

**PARALLEL INTERFACE TIMING DIAGRAM (6800 MODE)**

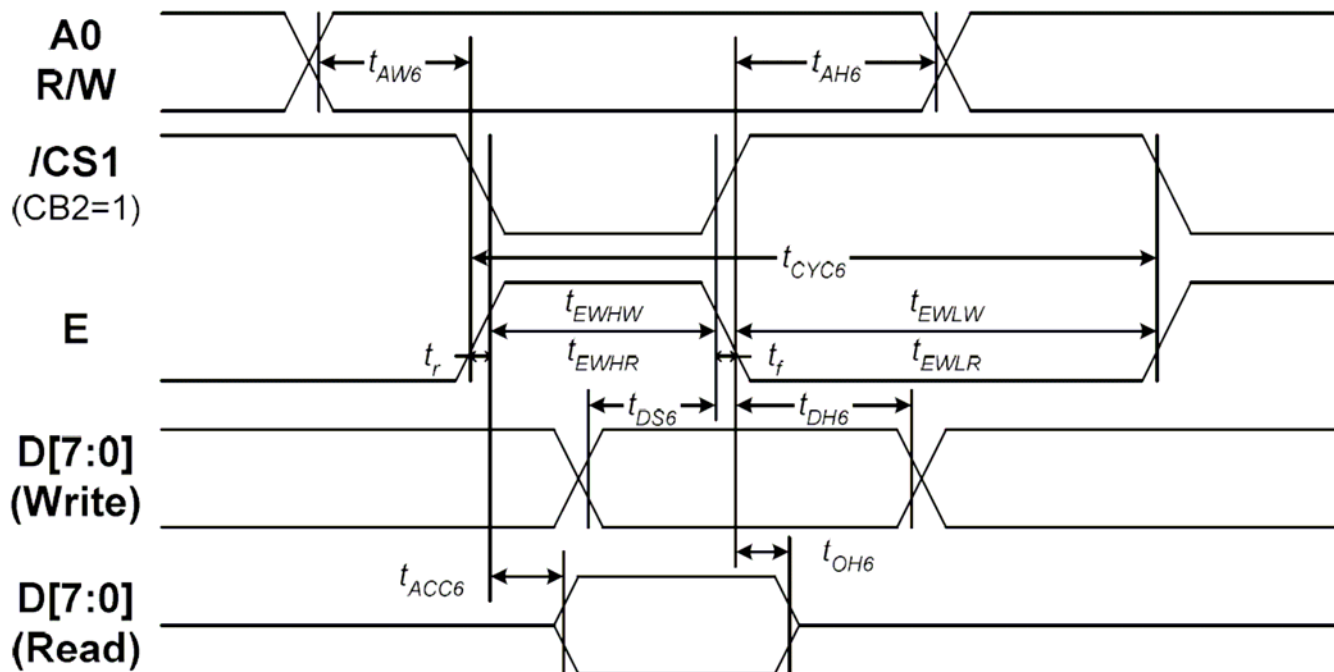

**PARALLEL INTERFACE TIMING CHARACTERISTICS (6800 MODE)**

(VDD = 3.3V, Ta = -30 to 85°C)

Item	Signal	Symbol	Condition	Rating		Units
				Min.	Max.	
Address hold time	A0	t <sub>AH6</sub>		0	—	ns
Address setup time		t <sub>AW6</sub>		0	—	
System cycle time		t <sub>CYC6</sub>		240	—	
Enable L pulse width (WRITE)	E	t <sub>EWLW</sub>		80	—	
Enable H pulse width (WRITE)		t <sub>EWHW</sub>		80	—	
Enable L pulse width (READ)		t <sub>EWLR</sub>		80	—	
Enable H pulse width (READ)		t <sub>EWHR</sub>		140	—	
WRITE Data setup time	D0 to D7	t <sub>DS6</sub>		40	—	
WRITE Address hold time		t <sub>DH6</sub>		0	—	
READ access time		t <sub>ACC6</sub>	CL = 100 pF	—	70	
READ Output disable time		t <sub>OH6</sub>	CL = 100 pF	5	50	

**SERIAL INTERFACE TIMING DIAGRAM**

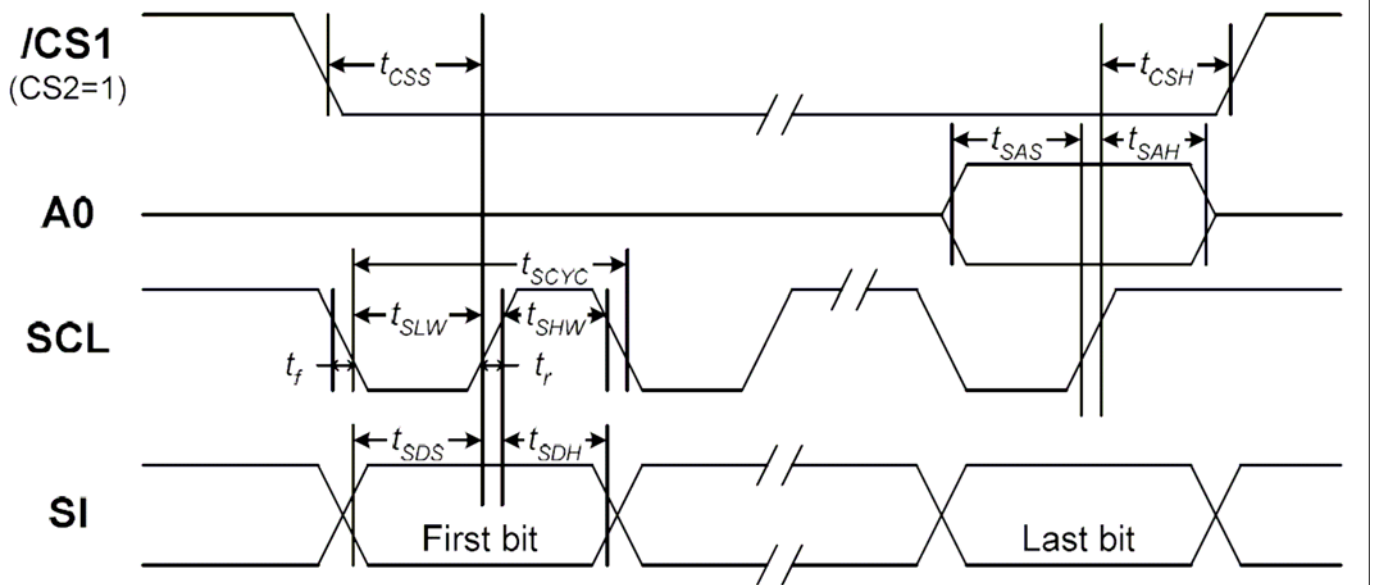

### SERIAL INTERFACE TIMING CHARACTERISTICS

( $V_{DD} = 3.3V$ ,  $T_a = -30$  to  $85^\circ C$ )

Item	Signal	Symbol	Condition	Rating		Units
				Min.	Max.	
Serial Clock Period	SCL	$t_{SCYC}$		50	—	ns
SCL "H" pulse width		$t_{SHW}$		25	—	
SCL "L" pulse width		$t_{SLW}$		25	—	
Address setup time	A0	$t_{SAS}$		20	—	
Address hold time		$t_{SAH}$		10	—	
Data setup time	SI	$t_{SDS}$		20	—	
Data hold time		$t_{SDH}$		10	—	
CS-SCL time	CS	$t_{CSS}$		20	—	
CS-SCL time		$t_{CSH}$		40	—	

## RESET TIMING DIAGRAM

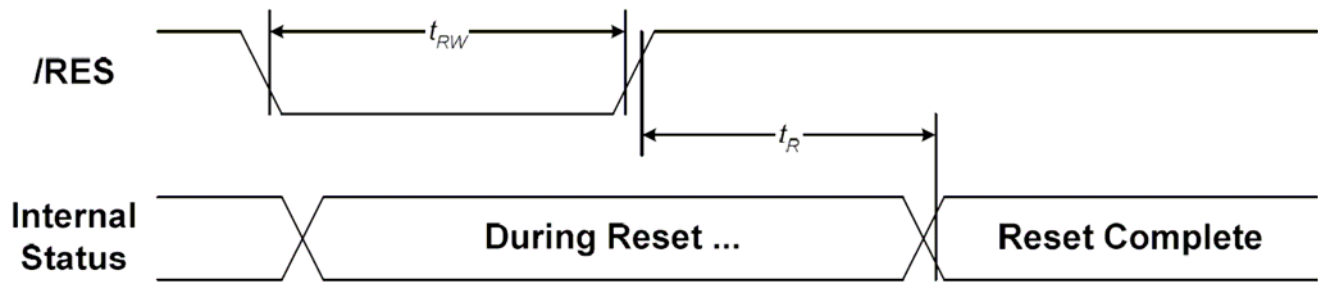

## RESET TIMING

(V<sub>DD</sub> = 3.3V, T<sub>a</sub> = -30 to 85°C)

Item	Signal	Symbol	Condition	Rating			Units
				Min.	Typ.	Max.	
Reset time	/RES	$t_R$		—	—	1.0	μs
Reset "L" pulse width		$t_{RW}$		1.0	—	—	μs

## INITIALIZING WITHOUT THE BUILT-IN POWER SUPPLY CIRCUITS

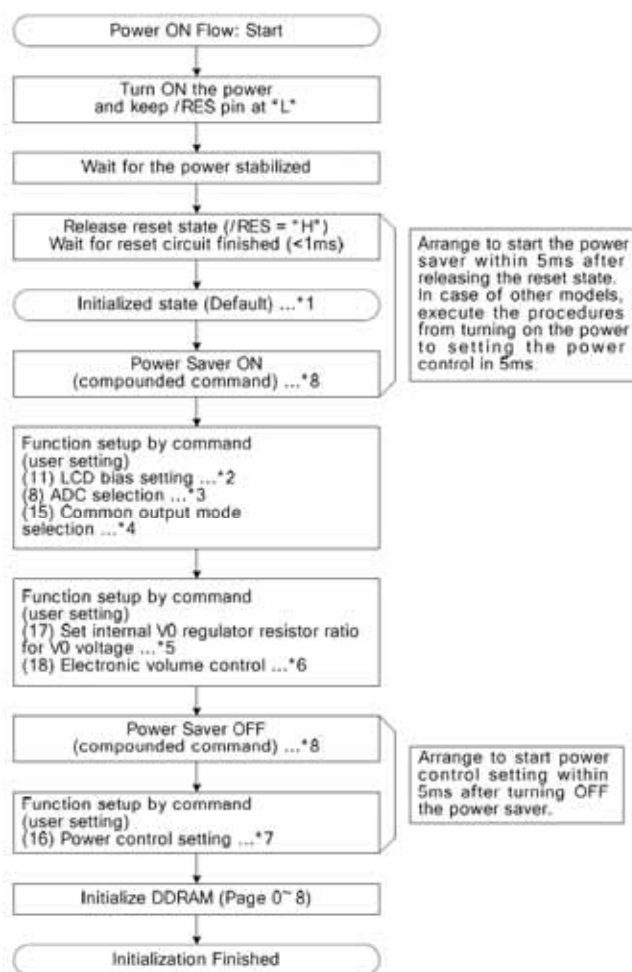

\* The target time of 5ms will result to vary depending on the panel characteristics and the capacitance of the smoothing capacitor. Therefore, we suggest you to conduct an operation check using the actual equipment.

Notes: Refer to respective sections or paragraphs listed below.

\*1: Description of functions; Resetting circuit

\*2: Command description; LCD bias setting

\*3: Command description; ADC selection

\*4: Command description; Common output state selection

\*5: Description of functions; Power circuit & Command description; Setting the built-in resistance ratio for regulation of the V0 voltage

\*6: Description of functions; Power circuit & Command description; Electronic volume control

\*7: Description of functions; Power circuit & Command description; Power control setting

\*8: The power saver ON state can either be in sleep state or stand-by state.

Command description; Power saver START (multiple commands)

**ELECTRO-OPTICAL CHARACTERISTICS**

MEASURING CONDITION: POWER SUPPLY =  $V_{OP} / 64 \text{ Hz}$   
 TEMPERATURE =  $23 \pm 5 \text{ }^\circ\text{C}$   
 RELATIVE HUMIDITY =  $60 \pm 20 \%$

ITEM	SYMBOL	UNIT	TYP. STN
RESPONSE TIME	T <sub>on</sub>	ms	220
	T <sub>off</sub>	ms	280
CONTRAST RATIO	Cr	-	12
VIEWING ANGLE (Cr ≥ 2)	V3:00	°	40
	V6:00	°	70
	V9:00	°	40
	V12:00	°	50

THE ELECTRO-OPTICAL CHARACTERISTICS ARE MEASURED VALUE BUT NOT GUARANTEED ONES.

**RELIABILITY OF LCD MODULE**

ITEM	TEST CONDITION FOR NORMAL TEMPERATURE	TEST CONDITION FOR WIDE TEMPERATURE	TIME
High temperature operating	50°C	70°C	240 hours
Low temperature operating	0°C	-20°C	240 hours
High temperature storage	60°C	80°C	240 hours
Low temperature storage	-10°C	-30°C	240 hours
Temperature-humidity storage	40°C 90% R.H.	60°C 90% R.H.	96 hours
Temperature cycling	-10°C to 60°C 30 Min Dwell	-30°C to 80°C 30 Min Dwell	5 cycle
Vibration Test at LCM Level	Freq 10-55 Hz Sweep rate: 10-55-10 at 1 min Sweep mode Linear Displacement: 2 mm p-p 1 Hour each for X, Y, Z	Freq 10-55 Hz Sweep rate: 10-55-10 at 1 min Sweep mode Linear Displacement: 2 mm p-p 1 Hour each for X, Y, Z	—

**QUALITY STANDARD OF LCD MODULE**

<b>1.0</b>	<b>Sampling Method</b>		
	Sampling Plan : MIL STD 105 E Class of AQL : Level II/Single Sampling Critical : 0.25% Major 0.65% Minor 1.5%		
<b>2.0</b>	<b>Defect Group</b>	<b>Failure Category</b>	<b>Failure Reasons</b>
	Critical Defect 0.25%(AQL)	Malfunction	Open Short Burnt or dead component Missing part/improper part P.C.B. Broken
	Major Defect 0.65%(AQL)	Poor Insulation	Potential short High current Component damage or scratched or Lying too close improper coating
		Poor Conduction	Damage joint Wrong polarity Wrong spec. part Uneven/intermittent contact Loose part Copper peeling Rust or corrosion or dirt's
	Minor Defect 1.5%(AQL)	Cosmetic Defect	Minor scratch Flux residue Thin solder Poor plating Poor marking Crack solder Poor bending Poor packing Wrong size

**SAMPLING METHOD**

SAMPLING PLAN: MIL-STD 105E

CLASS OF AQL: LEVEL II/ SINGLE SAMPLING  
 MAJOR-0.65% MINOR – 1.5%

**QUALITY STANDARD**

DEFECT	CRITERIA	TYPE	FIGURE
SHORT CIRCUIT	-	MAJOR	-
MISSING SEGMENT	-	MAJOR	-
UNEVEN / POOR CONTRAST	-	MAJOR	-
CROSS TALK	-	MAJOR	-
PIN HOLE	$MAX(a,b) \leq 1 / 4 W$	MINOR	1
EXCESS SEGMENT	$MAX(c,d) \leq 1 / 4 T$	MINOR	1
BUBBLES	$d^* \geq 0.2$ QTY=0	MINOR	2
BLACKS SPOTS	$d \leq 0.3$ N.A.** $0.3 < d \leq 0.4$ QTY $\leq$ 1 $0.4 < d$ QTY=0	MINOR	2
LINE SCRATCHES	$x \geq 0.7$ $y \geq 0.05$ QTY=0	MINOR	3
BLACK LINE	$x \geq 0.7$ $y \geq 0.05$ QTY=0	MINOR	3

\*d = MAX (d<sub>1</sub>,d<sub>2</sub>)

\*\* N. A . = NOT APPLICABLE

DEFECT TABLE : B

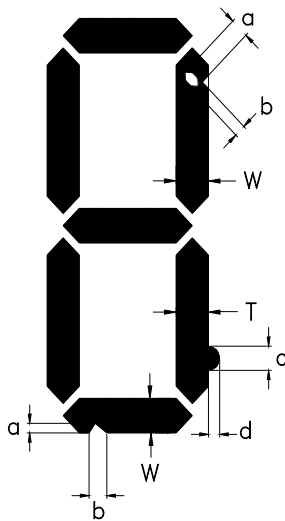
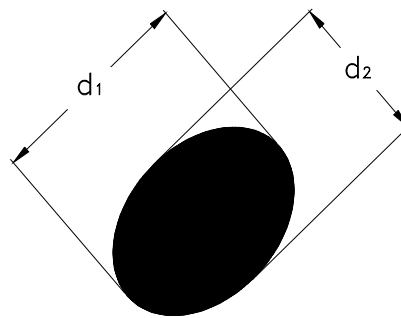
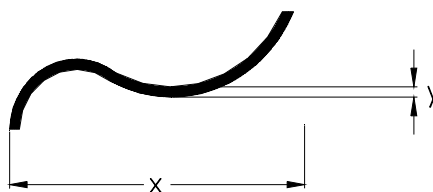

fig . 1



POLARIZER BUBBLES / SPOTS

fig . 2



LINE SCRATCHES / BLACK LINE

fig . 3

QUALITY STANDARD ( CONT . )

DEFECT		CRITERIA	TYPE	FIGURE
CHIPS	CONTACT EDGE	$e \leq 1/2T$ $f \leq 1/3W$ $g \leq 3.5$	MINOR	4
	BOTTOM GLASS	$p \leq 1.0$ $q \leq 3.5$ $r \leq 1/2T$		4
	CORNER	$a \leq 1.5$ $b \leq W$		4
	TOP GLASS	$a \leq 3.0$ $b \leq 1/3T$ $c \leq 1/2W$		5
GLASS PROTRUSION		$a \leq 1/4 W$	MINOR	6
RAINBOW		-	MINOR	-

UNLESS STATE OTHERWISE , ALL UNIT ARE IN MILLIMETER .

DEFECT TABLE : B

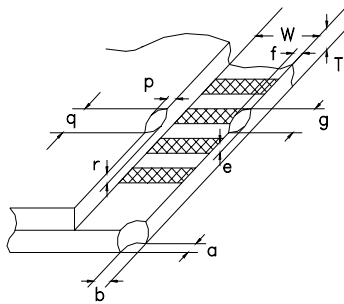

fig . 4

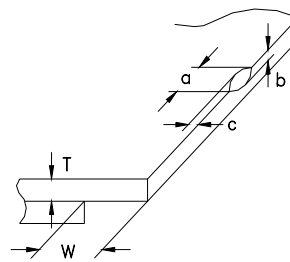

fig . 5

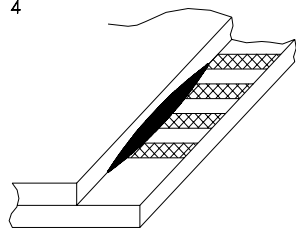
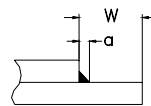

fig . 6



## HANDLING PRECAUTIONS

### (1) CAUTION OF LCD HANDLING & CLEANING

The polarizing plate on the surface of the panel is made from organic substances. Be very careful for chemicals not to touch the plate or it leads the polarizing plate to deteriorate.

If the use of a chemical is unavoidable, wipe the panel lightly with soft materials, such as gauze and absorbent cotton, soaked in a solvent.

\*Usable solvent: Alcohol (ethanol, IPA and the like)

\*Appropriate solvent: Ketones, ethyl alcohol

Avoid wiping with a dry cloth, since it could damage the surface of the polarizing plate and others.

### (2) CAUTION AGAINST STATIC CHARGE

The LCD modules use CMOS LSI drivers, so customers are recommended that any unused input terminal would be connected to  $V_{DD}$  or  $V_{SS}$ , do not input any signals before power is turned on, and ground your body, work/assembly areas, assembly equipment to protect against static electricity.

### (3) ESD PRECAUTION

Inputs and outputs are protected against electrostatic discharge in normal handling. However, to be totally safe, it is recommended to take normal precautions appropriate to handling LCM module. For example: product surface grounding. Always take ESD precaution when handling the *LCD Module*. Components are exposed for direct finger touches and can be damaged unless ESD precaution is taken.

### (4) PACKAGING

Avoid intense shock and falls from a height and do not operate or store them exposed to direct sunshine or high temperature/humidity for long periods.

### (5) CAUTION FOR OPERATION

The viewing angle can be adjusted by varying the LCD driving voltage  $V_O$ .

Driving voltage should be kept within specified range, excess voltage shortens display life.

Response time increases with decrease in temperature.

Display may turn black or dark Blue at temperature above its operational range; this is however not destructive and the display will return to normal once the temperature falls back to range.

Mechanical disturbance during operation (such as pressing on the viewing area) may cause the segments to appear "fractured". They will recover once the display is turned off.

Condensation at terminals will cause malfunction and possible electrochemical reaction. Relative humidity of the environment should therefore be kept below 60%.

### (6) SAFETY

Liquid crystal may leak out of a damaged LCD, it is recommended to wash off the liquid crystal by using solvents such as acetone or ethanol and should be burned up later.

If any liquid leak out of a damaged glass cell comes in contact with your hands, wash it off with soap and water immediately.

## WARRANTY

CLOVER will replace or repair any of her LCD module in accordance with her LCD specification for a period of one year from date of shipment. The warranty liability of Clover is limited to repair and/or replacement. Clover will not be responsible for any subsequent or consequential event.